



# Inspection Report

**Rick Smyth**

**Property Address:**

1243 Main Lane  
San Diego CA 92128



## The Property Inspection Pros

**Jeff Duncan**  
**www.tpips.com**  
**jduncan@tpips.com**  
**Cell - 760-525-5340**  
**Certified Master Inspector**



## Table of Contents

<u>Cover Page.....</u>	<u>1</u>
<u>Table of Contents.....</u>	<u>3</u>
<u>Intro Page.....</u>	<u>4</u>
<u>1 Roofing.....</u>	<u>8</u>
<u>2 Exterior.....</u>	<u>9</u>
<u>3 Electrical System.....</u>	<u>11</u>
<u>4 Garage.....</u>	<u>16</u>
<u>5 Water Heater.....</u>	<u>21</u>
<u>6 Interiors.....</u>	<u>24</u>
<u>7 Plumbing System.....</u>	<u>30</u>
<u>8(A) Bathroom(s) / Hall Bathroom.....</u>	<u>35</u>
<u>8(B) Bathroom(s) / Master Bathroom.....</u>	<u>37</u>
<u>9 Laundry.....</u>	<u>39</u>
<u>10 Fireplaces/ Chimneys.....</u>	<u>41</u>
<u>11 Detectors, Safety, Security.....</u>	<u>44</u>
<u>12 Heating Equipment.....</u>	<u>46</u>
<u>13 Cooling Equipment.....</u>	<u>51</u>
<u>14 Ventilation and Insulation.....</u>	<u>55</u>
<u>15 Structural Components.....</u>	<u>56</u>
<u>16 Built-In Kitchen Appliances.....</u>	<u>57</u>
<u>17 Gas, Electric, Water Shut-Off Locations ....</u>	<u>61</u>
<u>General Summary.....</u>	<u>63</u>

<b>Date:</b> 9/18/2024	<b>Time:</b> 08:00 AM	<b>Report ID:</b>
<b>Property:</b> 1243 Main Lane San Diego CA 92128	<b>Customer:</b> Rick Smyth	<b>Real Estate Professional:</b>

<b>IN ATTENDANCE DURING THE INSPECTION:</b> BUYER, BUYER'S AGENT, INSPECTOR	<b>TYPE OF BUILDING:</b> TOWNHOME	<b>APPROXIMATE YEAR BUILT (BASED ON BUYERS AGENT-BUYER-OR/MLS):</b> 1992
<b>WEATHER TYPE:</b> CLEAR	<b>TEMPERATURE:</b> 72, DEGREES	<b>GROUND/ SOIL SURFACE CONDITIONS:</b> DRY
<b>RAINED IN THE LAST 3 DAYS:</b> NO	<b>NUMBER OF LEVELS:</b> 2	<b>UTILITIES:</b> ALL UTILITIES WERE ON
<b>OCCUPIED:</b> YES		

**PLEASE READ THE FOLLOWING INFORMATION**

The purpose of this inspection is to assess the general condition of the property. Our Inspectors are Generalists and not Specialists. Further evaluated by licensed contractors who through their evaluations may identify additional material defects or adverse conditions that could result in injury or lead to costs that would significantly affect your evaluation of the property. We highly recommend that you follow our further evaluation recommendations as outlined in your inspection report prior to the end of your contingency period. Special attention is given to identifying deficiencies in systems and components that require immediate repair, or that need further investigation. Chips, cracks, blemishes, etc. that are cosmetic in nature are not reportable items. The Client(s) is/are therefore advised to inspect and evaluate such items personally and take corrective action(s) if concerned.

This report is the exclusive property of The Property Inspection Pros and the client(s) whose name appears herewith, and its use by any unauthorized persons is strictly prohibited. The observations and opinions expressed within this report are those of The Property Inspection Pros and supersede any alleged verbal comments. We inspect all of the systems, components, and conditions described in accordance with the International Association of Certified Home Inspectors Standards of Practice of a General Home Inspection.

**SCOPE OF THE INSPECTION:**

The Property Inspection Pros Inspectors will inspect all properties in accordance with the International Association of Certified Home Inspectors, Standards of Practice of a General Home Inspection. We respectfully ask that you read and become familiar with these Standards of Practice at the following link: **STANDARDS OF PRACTICE** If you have any questions or concerns of these Standard of Practice of a General Home Inspection please contact us 760-525-6154.

The Property Inspection Pros provides you with a basic overview of the condition of the property at the time

and date of the inspection. The purpose of your Home Inspection is to evaluate the general condition of the structure at the noted address. This includes determining whether systems are still performing their intended functions. The inspection to be performed for Client(s) is a limited, visual, non-invasive, non-destructive, nontechnically exhaustive evaluation, performed for a determined fee, designed to identify material defects in the systems, structures, and components of the above-referenced primary building and its associated primary parking structure as they exist at the time and date of the inspection. A material defect is a condition that significantly affects the value, desirability, habitability or safety of the building. Style or aesthetics shall not be considered in determining whether a specific system, structure, or component is defective. The inspection shall be limited to those specific systems, structures, and components that are present and visually accessible at the date and time of the inspection. Components and systems shall be operated with normal user controls only and as conditions and limitations permit. The inspection provides a general overview of the more obvious repairs or replacement that may be needed. It is not intended to be an exhaustive list. The ultimate decision of what to repair or replace is yours. One homeowner may decide that certain conditions require repair or replacement, while another will not. There are limitations to the scope of this Inspection.

The inspection report shall describe and identify the inspected systems, structures, and components of the building and identify material defects in those systems, structures, and components observable during the inspection, with limitations. Defects that are concealed/ are not accessible are specifically disclaimed. This includes defects that are concealed in/ behind the walls and wall coverings, in/ behind the floors and floor coverings, concealed by fresh paint, soil, vegetation, or other landscaping, or by stored items throughout the interior or exterior of the house/ property. Client(s) understands that the inspector shall use specialized tools at aid in the inspection process with the Client(s) best interest in mind, but that some concealed defects may go undetected and are unable to be reported on. Inspectors will not find conditions that may only be visible when storage or furniture is moved. Inspectors do not remove wallpaper, look behind pictures, and move furniture / stored items, lift flooring (including carpet) to look underneath, or cut / remove vegetation / landscaping. Client(s) agrees to hold the Inspector and The Property Inspection Pros harmless if Client(s) or any of the Client(s) representatives discovers concealed defects that were undetected at the time and date of the inspection.

#### **LIMITATIONS, EXCEPTIONS AND EXCLUSIONS:**

Excluded from this limited, visual, non-intrusive, non-destructive, non-technically exhaustive generalist inspection of the structure is any system, structure, or component of the building which is inaccessible, concealed from view, or cannot be inspected due to circumstances beyond the control of Inspector, or which Client(s) has agreed is not to be inspected. In addition to concealed defects, the following are excluded from the scope of this inspection unless specifically agreed to in writing:

1. Determining compliance with each manufacturers' specifications, researching building codes for the year built or modified, ordinances, regulations, covenants, or other restrictions (such as HOA rules), including local interpretations thereof.
2. Obtaining or reviewing information from any third-parties including, but not limited to: government agencies (such as permits), component or system manufacturers (including product defects, recalls or similar notices, unless agreed to in writing), square footage, contractors, managers, sellers, occupants, neighbors, consultants, homeowner or similar associations, attorneys, agents or brokers. The Property Inspection Pros does not endorse nor inspect unpermitted structures or additions and exclusively disclaims them from our inspection and inspection report. Geotechnical, engineering, structural, architectural, geological, hydrological, land surveying or soils-related examinations.
3. Examination of conditions related to animals, rodents, insects, wood-destroying insects, organisms, mold, and mildew or the damage caused thereby. Mold determination is not part of this inspection (unless agreed to in writing). If evidence of unidentified stains is noted, a specialist should be consulted to determine type. Mold has been known to cause health risks. The Inspector does not look for, or comment on, the past use of chemical termite treatments in or around the property.
4. Certain factors relating to any systems, structures, or components of the building, including, but not limited to: Recalls, adequacy, efficiency, durability or remaining useful life, costs to repair, replace or operate, fair market value, marketability, quality, or advisability of purchase.
5. Environmental hazards or conditions, including, but not limited to, toxic, reactive, combustible, corrosive contaminants, wildfire, geologic or flood.
6. Dismantling of any system, structure, or component, or perform any intrusive or destructive examination, test or analysis. Inspector is limited to evaluating components from standard service or access covers.
7. Examining or evaluating fire-resistive qualities of any system, structure or component of the building.
8. Systems, structures, or components of the building, which are not permanently installed (such

as refrigerators, washing machines and dryers, window AC, etc). 9. Systems, structures, or components that are not part of the main house, unless specifically identified in the written inspection report. 10. Common areas, or systems, structures, or components thereof, including, but not limited to, those of a common interest (HOA). 11. Examining or evaluating the acoustical or other nuisance characteristics of any system, structure, or component of a building, complex, adjoining properties, or neighborhood. 12. Operating or evaluating low voltage electrical, antennas, security systems, cable or satellite television, telephone, remote controls, radio controls, timers, intercoms, computers, computer networks, photo-electric, motion sensing, or other such similar non-primary electrical power devices, exterior yard lighting, components, or systems. 13. Evaluation of any pool/spa, barn, fence, irrigation system, built in BBQs or other structures unless agreed to in writing. 14. Evaluation of any type of electric Solar system and related components on or off the house/ structure. 15. Examining or operating any sewage disposal system or component including, but not limited to: septic tanks and/or any underground system or portion thereof, or ejector pumps for rain or waste. 16. Environmental evaluation and inspection. The building inspection is not intended to determine the presence of lead, radon, mold, Polychlorinated biphenyls (PCB's), mildew, urea- formaldehyde, asbestos, sulfur, contaminated drywall, Chinese drywall, or other toxins in the building, ground, water or air. 17. It is beyond the scope of this inspection to determine if any system or component is, has been, or will be part of any product, component or system recall. We highly recommend Client(s) subscribe or contact the CPSC (Consumer Product Safety Commission) for recall information regarding any system or component if concerned.

A home inspection is not a pest inspection. Any observations which the inspector may make in this report regarding evidence of peats or wood destroying organisms, are not a substitute for an inspection by a qualified licensed pest control operator or exterminator. Your inspector may only report on a portion of the currently visible conditions and cannot render an opinion regarding their cause, condition, or remediation. We recommend a careful review of any recent pest control inspection report concerning pest activity or wood destroying organisms on this property. If no such report is available, we recommend that a pest control inspection be performed on the property prior to the end of your contingency period.

Thank you for choosing The Property Inspection Pros for your property inspection needs. We hope the information contained in your report is beneficial to you. If there are areas that you have questions about or would like further explanation, please don't hesitate to call us. Your satisfaction is important to us.

### **Comment Key or Definitions**

The following definitions of comment descriptions represent this inspection report. All comments by the inspector should be considered before purchasing this home. Any recommendations by the inspector to repair or replace suggests a second opinion or further inspection by a qualified contractor. All costs associated with further inspection fees and repair or replacement of item, component or unit should be considered before you purchase the property.

**Inspected (IN)** = I visually observed the item, component or unit and if no other comments were made then it appeared to be functioning as intended allowing for normal wear and tear.

**Not Inspected (NI)**= I did not inspect this item, component or unit and made no representations of whether or not it was functioning as intended and will state a reason for not inspecting.

**Not Present (NP)** = This item, component or unit is not in this home or building.

**Repair or Replace (RR)** = The item, component or unit is not functioning as intended, or needs further

inspection by a qualified contractor. Items, components or units that can be repaired to satisfactory condition may not need replacement.

**Information Only (IO)** = This item, is for your information only.

Please accept this one year FREE membership to HOCOA your home repair network on my behalf. It's easy to get started just go to this link [HOCOA](#) and fill out the short form. You will then receive your FREE membership kit in the mail in a few days.

THE TERMS 'FRONT,' 'REAR,' 'LEFT,' AND 'RIGHT' ARE USED IN REFERENCE TO THE PROPERTY AS VIEWED FROM THE FRONT ENTRY DOOR.

Inspected in accordance with "THE INTERNATIONAL ASSOCIATION OF CERTIFIED HOME INSPECTORS STANDARDS OF PRATICE AND CODE OF ETHICS".

## 1. Roofing

The home inspector shall observe: Roof covering; Roof drainage systems; Flashings; Skylights, chimneys, and roof penetrations; and Signs of leaks or abnormal condensation on building components. The home inspector shall: Describe the type of roof covering materials; and Report the methods used to observe the roofing. The home inspector is not required to: Walk on the roofing; or Observe attached accessories including but not limited to solar systems, antennae, and lightning arrestors. We do not verify that the materials are installed according to manufacturer's specifications. We recommend that all stains be further evaluated by a qualified licensed roof contractor prior to the end of your contingency period and repaired as necessary.



Note: We recommend that all roofs be inspected and maintained periodically by a qualified licensed roof contractor.

IN= Inspected, NI= Not Inspected, NP= Not Present, RR= Repair or Replace, IO= Information Only

**IN NI NP RR IO Items**

**1.0 ROOFING - CONDO**

**Comments:**

This inspection is being performed on a condominium. A condo inspection is limited to the interior space only, and does not include the roof in any way. Please contact the HOA for information regarding the condition of the roof, repair history, or any other roof concerns.

**IN NI NP RR IO Items**

IN= Inspected, NI= Not Inspected, NP= Not Present, RR= Repair or Replace, IO= Information Only

The roof of the home was inspected and reported on with the above information. While the inspector makes every effort to find all areas of concern, some areas can go unnoticed. Roof coverings and skylights can appear to be leak proof during inspection and weather conditions. Our inspection makes an attempt to find a leak but sometimes cannot. Please be aware that the inspector has your best interest in mind. However, we do not predict the remaining life, the integrity, or guarantee that the roof will not leak. We also recommend obtaining a home warranty that includes coverage for the roof (s). Any repair items mentioned in this report should be considered before purchase. It is recommended that qualified licensed contractors be used in your further inspection or repair issues as it relates to the comments in this inspection report.

Note: This roof inspection reports on the type and condition of the roofing materials, missing and/or damaged materials, and attachments (excluding solar systems, antennas, etc.) where visible. This does not constitute a warranty, guarantee, roof certification, or life expectancy evaluation of any kind. Roofs are not water tested for leaks. The condition of the roofing underlayment material was not verified/inspected. For further evaluation and a roof certification, we recommend you consult a qualified licensed roofing contractor prior to the end of your contingency period.



## 2. Exterior

The home inspector shall observe: Wall cladding, flashings, and trim; Entryway doors and a representative number of windows; Garage door operators; Decks, balconies, stoops, steps, areaways, porches and applicable railings; Eaves, soffits, and fascias; and Vegetation, grading, drainage, driveways, patios, walkways, and retaining walls with respect to their effect on the condition of the building. The home inspector shall: Describe wall cladding materials; Operate all entryway doors and a representative number of windows; Operate garage doors manually or by using permanently installed controls for any garage door operator; Report whether or not any garage door operator will automatically reverse or stop when meeting reasonable resistance during closing; and Probe exterior wood components where deterioration is suspected. The home inspector is not required to observe: Storm windows, storm doors, screening, shutters, awnings, and similar seasonal accessories; Fences; Presence of safety glazing in doors and windows; Garage door operator remote control transmitters; Geological conditions; Soil conditions; Recreational facilities (including spas, saunas, steam baths, swimming pools, tennis courts, playground equipment, and other exercise, entertainment, or athletic facilities); Detached buildings or structures; or Presence or condition of buried fuel storage tanks. The home inspector is not required to: Move personal items, panels, furniture, equipment, plant life, soil, snow, ice or debris that obstructs access or visibility.



Property Notes: Identifying the location of property lines, easements, and other property restrictions, and their implications to existing structures are beyond the scope of our general home inspection.

IN= Inspected, NI= Not Inspected, NP= Not Present, RR= Repair or Replace, IO= Information Only

**IN NI NP RR IO Items**

**2.0 EXTERIOR CONDO**

**Comments:**

The exterior was not evaluated as part of this condo inspection. A condo inspection is limited to the interior only and not an evaluation of the exterior. Common areas are not part of a condo inspection. If concerned we recommend contacting the HOA prior to the end of your contingency period.

**2.1 WALL CLADDING FLASHING AND TRIM**  
**SIDING MATERIAL: STUCCO**

**2.2 DOORS (EXTERIOR)**

**Comments:**

(1) The door has a torn or damaged screen. We recommend repair or replacement by a qualified person.



2.2 Item 1(Picture)

**IN NI NP RR IO Items**

IN= Inspected, NI= Not Inspected, NP= Not Present, RR= Repair or Replace, IO= Information Only

IN NI NP RR IO Items

(2) The deck door weather-stripping is damaged. We recommend replacement by a qualified person.



2.2 Item 2(Picture)

• □ □ □ □ 2.3 WINDOWS (INTERIOR AND EXTERIOR)

WINDOWS: AGED/ WORN, DOUBLE PANE ALUMINUM

Comments:

Dual Pane Window Note - Failed seals in insulated glass dual pane windows are not always visible or detectable. In some instances the home inspector may not be able to disclose the exact condition of every window, depending on the ambient conditions or if the windows are dirty at the time of the inspection. Windows are reported as they are observed at the time of the inspection only. If you have present or future concerns regarding the integrity of the dual pane thermal seals, we strongly recommend that you consult with a qualified licensed window contractor for further evaluation. This inspection is not a guarantee of any kind regarding the integrity of the dual pane windows.

• □ □ □ □ 2.4 SAFETY GLASS (EXTERIOR)

IN NI NP RR IO Items

IN= Inspected, NI= Not Inspected, NP= Not Present, RR= Repair or Replace, IO= Information Only

The exterior of the home was inspected and reported on with the above information. While the inspector makes every effort to find all areas of concern, some areas can go unnoticed. Please be aware that the inspector has your best interest in mind. Any repair items mentioned in this report should be considered before purchase. It is recommended that qualified licensed contractors be used in your further inspection or repair issues as it relates to the comments in this inspection report.

### 3. Electrical System

The home inspector shall observe: Service entrance conductors; Service equipment, grounding equipment, main over current device, and main and distribution panels; Amperage and voltage ratings of the service; Branch circuit conductors, their over current devices, and the compatibility of their ampacities and voltages; The operation of a representative number of installed ceiling fans, lighting fixtures, switches and receptacles located inside the house, garage, and on the dwelling's exterior walls; The polarity and grounding of all receptacles within six feet of interior plumbing fixtures, and all receptacles in the garage or carport, and on the exterior of inspected structures; The operation of ground fault circuit interrupters; and Smoke detectors. The home inspector shall describe: Service amperage and voltage; Service entry conductor materials; Service type as being overhead or underground; and Location of main and distribution panels. The home inspector shall report any observed aluminum branch circuit wiring. The home inspector shall report on presence or absence of smoke detectors, and operate their test function, if accessible, except when detectors are part of a central system. The home inspector is not required to: Insert any tool, probe, or testing device inside the panels; Test or operate any over current device except ground fault circuit interrupters; Dismantle any electrical device or control other than to remove the covers of the main and auxiliary distribution panels; or Observe: Low voltage systems; Security system devices, heat detectors, or carbon monoxide detectors; Telephone, security, cable TV, intercoms, or other ancillary wiring that is not a part of the primary electrical distribution system; or Built-in vacuum equipment.



IN= Inspected, NI= Not Inspected, NP= Not Present, RR= Repair or Replace, IO= Information Only

**IN NI NP RR IO Items**

**3.0 SUB PANEL**

**Comments:**

**Photo of the sub electrical panel.**



3.0 Item 1(Picture)

**3.1 CIRCUIT BREAKERS/ FUSES**

**PANEL TYPE:** CIRCUIT BREAKERS

**Comments:**

**IN NI NP RR IO Items**

IN= Inspected, NI= Not Inspected, NP= Not Present, RR= Repair or Replace, IO= Information Only

**Photo inside of the sub electrical panel.**

The dead front cover was removed at the time of the inspection and the breakers, wiring and grounding were inspected. Appears to be functioning as intended.

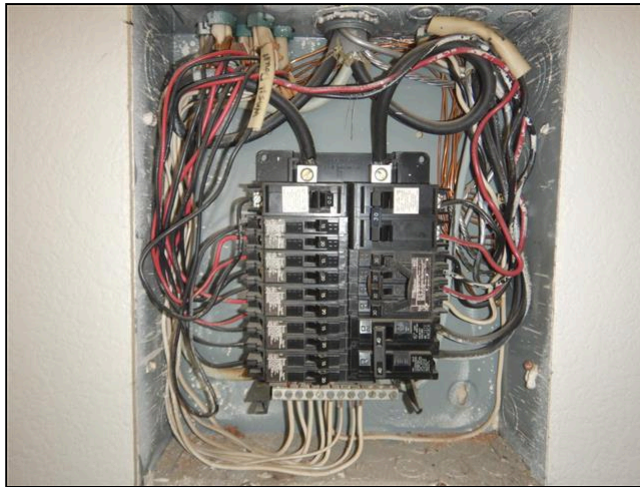

3.1 Item 1(Picture)

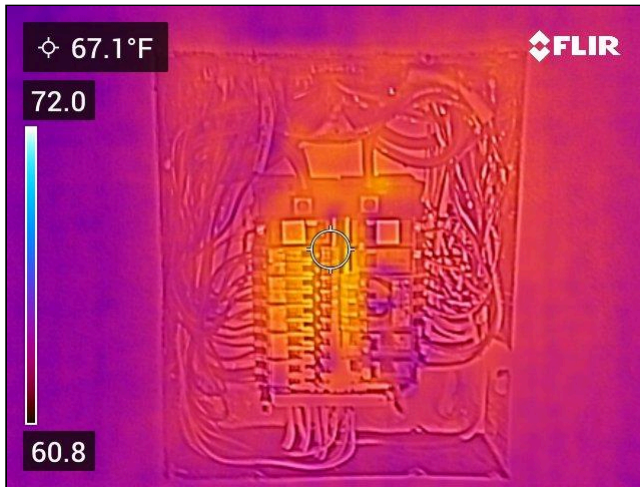

3.1 Item 2(Picture)



**3.2 BRANCH CIRCUIT CONDUCTORS/ WIRING**

**BRANCH WIRE 15 AND 20 AMP: COPPER**  
**WIRING METHODS: ROMEX**

**Comments:**

Home inspectors do not evaluate individual circuits for capacities, or identify which receptacles are on a particular circuit, or verify the labeling of the breakers. If concerned about the capacity of individual circuits for their capacities and the correct labeling of the breakers we recommend further evaluation by a qualified licensed electrician prior to the end of your contingency period for verification of these items.



**3.3 SERVICE AND GROUNDING EQUIPMENT**

IN NI NP RR IO Items

3.4 CONNECTED DEVICES AND FIXTURES (REPRESENTATIVE NUMBER)

3.5 SWITCHES

3.6 POLARITY AND GROUNDING (OF A REPRESENTATIVE NUMBER OF RECEPTACLES)

**Comments:**

(1) **Photo of a receptacle being tested.**

A representative number of receptacles throughout the property were tested for power, polarity and grounding according to our standards-of-practice. These receptacles observed to be ok at the time of the inspection unless otherwise noted.

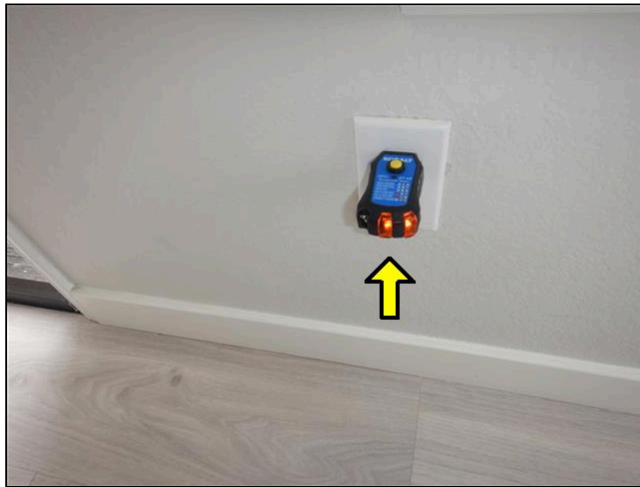

3.6 Item 1(Picture)

(2) **Photo of a receptacle being tested.**

A representative number of receptacles throughout the house and garage were tested for power, polarity and grounding according to our standards-of-practice. These receptacles observed to be ok at the time of the inspection unless otherwise noted.

3.7 RECEPTACLE(S) ISSUES

3.8 220 OUTLET(S)

3.9 OPERATION OF GFCI (GROUND FAULT CIRCUIT INTERRUPTERS)

**Comments:**

IN NI NP RR IO Items

IN= Inspected, NI= Not Inspected, NP= Not Present, RR= Repair or Replace, IO= Information Only



IN NI NP RR IO Items

(1) All accessible GFCI receptacles were tested and were functioning properly at the time of the inspection unless otherwise reported. Sometimes a tripped GFCI receptacle may be difficult to find. If you do not have power at certain receptacles please check all GFCI's and reset the tripped GFCI receptacle. If the GFCI doesn't reset than replacement of the GFCI receptacle will be required.

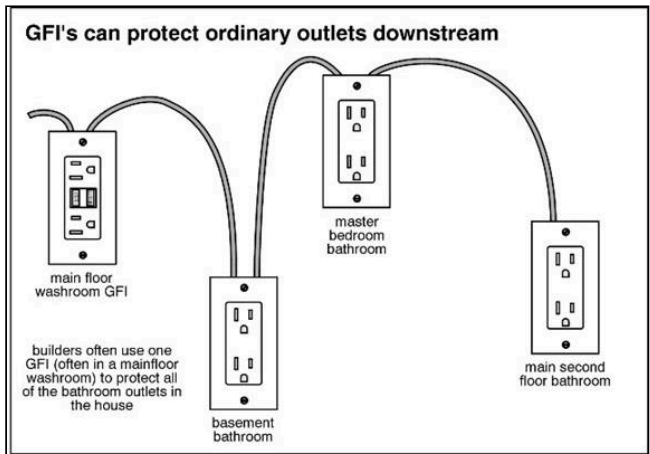

3.9 Item 1(Picture)

(2) We recommend upgrading all receptacles within 6 feet of any plumbing fixtures, outside/ exterior, in the garage, and any non fixed appliance receptacles in the kitchen to GFCI protected receptacles by a qualified licensed electrician for safety.



3.9 Item 2(Picture)

**3.10 OPERATION OF AFCI (ARC FAULT CIRCUIT INTERRUPTERS)**

**3.11 JUNCTION BOXES (OBSERVABLE)**

**3.12 EXTERIOR LIGHTING**  
 EXTERIOR LIGHTING CONTROL: STANDARD SWITCHED

**Comments:**

IN NI NP RR IO Items

IN= Inspected, NI= Not Inspected, NP= Not Present, RR= Repair or Replace, IO= Information Only

**IN NI NP RR IO Items**

---

A representative number of exterior lights were tested and were found to be functional at the time of the inspection.



3.12 Item 1(Picture)

**3.13 TELEPHONE AND CABLE ENTRANCE**

---

**IN NI NP RR IO Items**

IN= Inspected, NI= Not Inspected, NP= Not Present, RR= Repair or Replace, IO= Information Only

---

The electrical system of the home was inspected and reported on with the above information. While the inspector makes every effort to find all areas of concern, some areas can go unnoticed. Outlets were not removed and the inspection was only visual. Any outlet not accessible (behind the refrigerator for example) was not inspected or accessible. Please be aware that the inspector has your best interest in mind. Any repair items mentioned in this report should be considered before purchase. It is recommended that qualified licensed contractors be used in your further inspection or repair issues as it relates to the comments in this inspection report. All electrical concerns/ defects should be considered a safety concern and should be corrected.

## 4. Garage

The home inspector shall observe: Walls, ceiling, and floors; Steps, stairways, balconies, and railings; Garage door operators; Counters and a representative number of installed cabinets; and A representative number of doors and windows. The home inspector shall: Operate garage doors manually or by using permanently installed controls for any garage door operator; Report whether or not any garage door operator will automatically reverse or stop when meeting reasonable resistance during closing; Operate a representative number of windows and interior doors; and Report signs of abnormal or harmful water penetration into the building or signs of abnormal or harmful condensation on building components. The home inspector is not required to observe: Garage door operator remote control transmitters, Paint, wallpaper, and other finish treatments on the interior walls, ceilings, and floors; Carpeting; or Draperies, blinds, or other window treatments. The home inspector is not required to: Move personal items, panels, furniture, equipment that obstructs access or visibility.



IN= Inspected, NI= Not Inspected, NP= Not Present, RR= Repair or Replace, IO= Information Only

**IN NI NP RR IO Items**

**4.0 GARAGE VEHICLE DOOR(S)**

**GARAGE VEHICLE DOOR MATERIAL:** METAL - PANEL

**Comments:**

[Garage door photo\(s\).](#)

The garage vehicle door hardware including the door, track, and springs appear to be functioning as intended.



4.0 Item 1(Picture)

**IN NI NP RR IO Items**

IN= Inspected, NI= Not Inspected, NP= Not Present, RR= Repair or Replace, IO= Information Only





4.0 Item 2(Picture)

**4.1 GARAGE VEHICLE DOOR OPENER(S)**

**Comments:**

(1) Due to the high number of garage door openers that fail to auto-reverse when testing the garage door openers pressure-activated auto-reverse feature which could cause severe damage to the garage door and its related components when it fails to auto-reverse, we did not test the garage door openers pressure-activated auto-reverse feature at the time of the inspection. We recommend having the garage door(s) pressure-activated auto-reverse feature tested prior to the end of your contingency period by a qualified licensed garage door contractor.

(2) Sensors are in place, were tested and will reverse the garage door.

(3) The garage door push-button switch is lower than the recommended 5-foot minimum height above the standing surface. This condition is potentially dangerous to children. We recommend that the switch be raised to the 5-foot minimum or higher by a qualified licensed garage door contractor for safety reasons.

**4.2 GARAGE CEILING**

**Comments:**

The ceiling has typical cosmetic wear. You may wish to view this for yourself and have necessary repairs made by a qualified person.

**4.3 GARAGE WALLS (INCLUDING FIREWALL SEPERATION)**

**Comments:**

IN NI NP RR IO Items

(1) Due to occupants personal items, not all areas of the property were visible and accessible at the time of the inspection. Several windows, doors, outlets, walls, flooring, and other areas were obstructed from view and could not be inspected. The home inspector does not move personal items, panels, furniture, equipment, plant life, soil, debris, ect. that obstructs their access or visibility. We recommend that you conduct a careful evaluation during your final walk-through or prior to the end of your contingency period to ensure that there are no hidden defects. All doors, windows, and outlets should be tested and verified for proper operation prior to the end of your contingency period by a qualified person. If any damage is observed we recommend asking the seller about it. We recommend that any damage found be repaired or replaced by a qualified licensed contractor in the appropriate trade.



4.3 Item 1(Picture)

(2) The walls have typical cosmetic wear. You may wish to view this for yourself and have necessary repairs made as needed by a qualified person.



**4.4 GARAGE FLOOR/ SLAB**

**Comments:**

Due to stored personal items not all areas throughout the property were visible and accessible at the time of the inspection. The slab and other areas were obstructed from view and could not be inspected. The home inspector does not move personal items, panels, furniture, equipment, plant life, soil, debris, ect. that obstructs their access or visibility. We recommend that you conduct a careful evaluation during your final walk-through or prior to the end of your contingency period to ensure that there are no hidden defects. All doors, windows, and outlets should be tested and verified for proper operation prior to the end of your contingency period by a qualified person. If any damage is observed we recommend asking the seller about it. We recommend that any damage found be repaired or replaced by a qualified licensed contractor in the appropriate trade.



**4.5 FIRE-RATED DOOR**

**Comments:**

The door between the house and garage did not have a Fire Rating Certificate or Plate. Without a plate, I could not confirm whether the door meets fire code safety requirements. We recommend further evaluation by a licensed door contractor. The "fire door" is required to meet one of the following characteristics:1-3/8 inch thick solid wood, 1-3/8 inch thick steel shell door with Honeycomb core, Fire-rated (with certificate plate). If the door is not rated as a fire door we recommend replacing by a qualified licensed

IN NI NP RR IO Items

IN= Inspected, NI= Not Inspected, NP= Not Present, RR= Repair or Replace, IO= Information Only

IN NI NP RR IO Items

---

door contractor for safety.



4.5 Item 1(Picture)



**4.6 FIRE-DOOR CLOSING DEVICE**

**Comments:**

A self-closing device was present at the fire door and was operating properly when tested. The door closes and latches within 3 seconds without assistance as required.



4.6 Item 1(Picture)



**4.7 OUTLETS/ FIXTURES/ WIRING/ 220V**

**Comments:**

---

IN NI NP RR IO Items

IN= Inspected, NI= Not Inspected, NP= Not Present, RR= Repair or Replace, IO= Information Only

IN NI NP RR IO Items

---

There is an extension cord being used as wiring at the garage door opener. This is a non standard installation. We recommend having a permanent receptacle installed for use by the garage door opener by a qualified licensed electrician.



4.7 Item 1(Picture)

**4.8 POLARITY/ GROUNDING (RECEPTACLES)**

---

IN NI NP RR IO Items

IN= Inspected, NI= Not Inspected, NP= Not Present, RR= Repair or Replace, IO= Information Only

---

The garage was inspected and reported on with the above information. While the inspector makes every effort to find all areas of concern, some areas can go unnoticed. Please be aware that the inspector has your best interest in mind. Any repair items mentioned in this report should be considered before purchase. It is recommended that qualified licensed contractors be used in your further inspection or repair issues as it relates to the comments in this inspection report.

## 5. Water Heater

The home inspector shall observe: The water heating equipment, including the energy source, venting connections, temperature/pressure-relief (TPR) valves, Watts 210 valves, and seismic bracing, the capacity of the water heating equipment if labeled. The Temperature Pressure Relief (TPR) valve is not tested because the TPR valve is prone to leaking once activated. The inspector is not required to: measure the capacity, temperature, age, life expectancy or adequacy of the water heater, evaluate wait time to obtain hot water at fixtures, or perform testing of any kind to water heater elements.

IN= Inspected, NI= Not Inspected, NP= Not Present, RR= Repair or Replace, IO= Information Only

**IN NI NP RR IO Items**

**5.0 MAIN WATER HEATER (CONTROLS)**

**WATER HEATER YEAR MANUFACTURED:** 2021  
**WATER HEATER POWER SOURCE:** NATURAL GAS  
**WATER HEATER CAPACITY:** 40 GALLON

**Comments:**

- (1) [Photo of the water heater.](#)



5.0 Item 1(Picture)

**IN NI NP RR IO Items**

IN= Inspected, NI= Not Inspected, NP= Not Present, RR= Repair or Replace, IO= Information Only



5.0 Item 2(Picture)

(2) **Thermal Photo of the water temperature.**

The temperature of the water was tested using a thermal camera at the time of the inspection and found to be above 125 degrees. Water temperatures above 125 degrees can cause scalding or burns. Most water heater manufacturers recommend setting the water heater controls at 120 degrees for optimum efficiency. We recommend setting the water heater controls at 120 degrees by a qualified person for optimum efficiency.

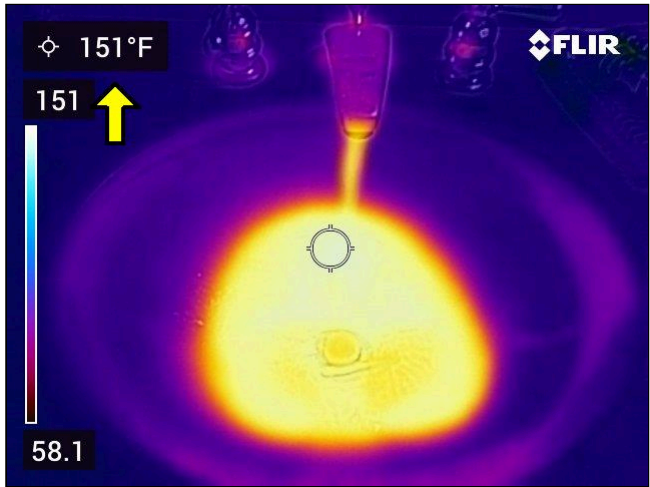

5.0 Item 3(Picture)

IN NI NP RR IO Items

(3) The water heater was inspected and was found to be operational at the time of the inspection. We did not evaluate the efficiency or recover rate of the water heater which is beyond the scope of a general home inspection. If concerned we recommend you consult a licensed plumber. We recommend flushing the water heater routinely as regular maintenance.

(4) The water heater does not have a "Thermal Expansion Tank" installed to prevent a possible leak at the T&P or "pop-off" valve. Recent changes in code require one when a new water heater is installed. This change is not retroactive on older previously installed Gas/LP water heaters. There were no leaks or drips at the T&P valve during inspection. If your water heater does begin to drip or leak, then a thermal expansion tank may be needed. We recommend installing a thermal tank by a qualified licensed plumber as an upgrade.

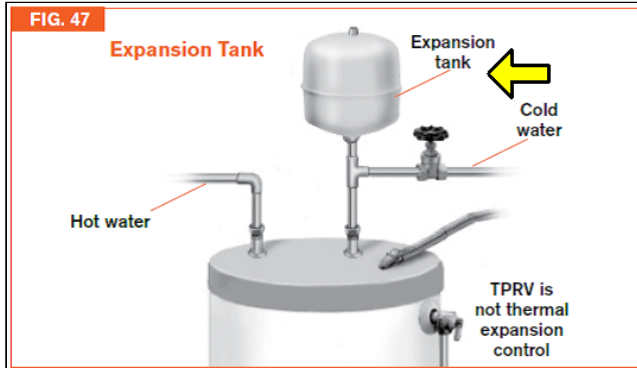

5.0 Item 4(Picture)

•

5.1 MAIN WATER HEATER (PLATFORM & STRAPPING)

Comments:

The water heater is adequately strapped as required.

•

5.2 MAIN WATER HEATER FLUE

•

5.3 MAIN WATER HEATER (TEMPERATURE & PRESSURE RELIEF VALVE)

IN NI NP RR IO Items

IN= Inspected, NI= Not Inspected, NP= Not Present, RR= Repair or Replace, IO= Information Only

The water heater in the home was inspected and reported on with the above information. While the inspector makes every effort to find all areas of concern, some areas can go unnoticed. If the water is turned off or not used for periods of time (like a vacant home waiting for closing) rust or deposits within the pipes can further clog the piping system. Please be aware that the inspector has your best interest in mind. Any repair items mentioned in this report should be considered before purchase. It is recommended that qualified licensed contractors be used in your further inspection or repair issues as it relates to the comments in this inspection report.



## 6. Interiors

The home inspector shall observe: Walls, ceiling, and floors; Steps, stairways, balconies, and railings; Counters and a representative number of installed cabinets; and A representative number of doors and windows. The home inspector shall: Operate a representative number of windows and interior doors; and Report signs of abnormal or harmful water penetration into the building or signs of abnormal or harmful condensation on building components. The home inspector is not required to observe: Paint, wallpaper, and other finish treatments on the interior walls, ceilings, and floors; Carpeting; or Draperies, blinds, or other window treatments. The home inspector is not required to: Move personal items, panels, furniture, equipment, or anything that obstructs access or visibility. Inspection of the home interior does not include testing for mold, radon, asbestos, lead paint, or other environmental hazards. If concerned we recommend further evaluation by a qualified licensed professional in the appropriate trade prior to the end of your contingency period.



Note: All moisture stains should be investigated until the client is satisfied that the condition is sufficiently understood. Where there are concerns regarding water leaks or infiltration, we recommend that a qualified industrial hygienist evaluate for mold, fungus, or other microbial material prior to the end of your contingency period.

Determining if damage, the presence of organic growths, moisture or wood rot behind walls, base boards, floors and ceiling coverings is beyond the scope of our general home inspection. If you are concerned or believe that these conditions may exist in a nonvisible or concealed area, we recommend that you have this home further examined by a qualified contractor or environmental hygienist prior to the end of your contingency period.

IN= Inspected, NI= Not Inspected, NP= Not Present, RR= Repair or Replace, IO= Information Only

**IN NI NP RR IO Items**



### 6.0 INTERIORS (GENERAL COMMENTS)

**WALL/ CEILING MATERIAL: SHEETROCK, OLDER**

**Comments:**

(1) A representative sampling for moisture was preformed at accessible interior walls using a moisture meter. (*areas prone to moisture, such as kitchens, bathrooms, below grade walls, exterior walls with doors/windows*). An elevated moisture was not detected at the time of the inspection.

(2) Determining if damage, the presence of organic growths, moisture or wood rot behind walls, floors and ceiling coverings is beyond the scope of our general home inspection. If you are concerned or believe that these conditions may exist in a nonvisible or concealed area, we recommend that you have this home further examined by a qualified contractor or environmental hygienist prior to the end of your contingency period.

(3) **A WORD ABOUT PHOTOS:** The photos in this report and their associated captions are included as a sampling of the conditions inspected. The photos are intended to clarify selected issues, but are NOT intended to imply their relative importance. Client(s) is advised that NOT all defects will be supported with photos and that NOT all photos taken will be used in the report. If similar defects are found at several locations throughout the property, only a representative number of photos may be shown in this report. Repairs should not be limited to only those areas, but at all instances of the defect(s). Sometimes it is not possible to take a photograph of a defect due to location, lighting, or other obstructions. Numerous photos may be taken of a property but not all will necessarily be included with a corresponding comment in the report. Only a sample number of photos are used and it's MOST important to use and go off the written comment and written information provided in your report. Please reach out to your inspector to request additional photos of an area or item you would want included.

(4) **We did not test the property for asbestos. Testing for asbestos is out of the scope of a general home inspection and was not done by this company at the time of the inspection. If your concerned that the this property may contain**

**IN NI NP RR IO Items**

IN= Inspected, NI= Not Inspected, NP= Not Present, RR= Repair or Replace, IO= Information Only



IN NI NP RR IO Items

**asbestos, we recommend that you have the property tested for asbestos prior to the end of your contingency period by a qualified licensed contractor.**

(5) This home is older and the home inspector considers this while inspecting. It is common to have areas that no longer comply with current code. This is not a new home and this home cannot be expected to meet current code standards. While this inspection makes every effort to point out safety issues, it does not inspect for code. It is common that homes of any age will have had repairs performed and some repairs may not be in a workmanlike manner. Some areas may appear less than standard. This inspection looks for items that are not functioning as intended. It does not grade the repair. It is common to see old plumbing or mixed materials. Sometimes water signs in crawlspaces or basements could be years old from a problem that no longer exists. Or, it may still need further attention and repair. Determining this can be difficult on an older home. Sometimes in older homes there are signs of damage to wood from wood eating insects. Having this is typical and fairly common. If the home inspection reveals signs of damage you should have a pest control company inspect further for activity and possible hidden damage. The home inspection does not look for possible manufacturer re-calls on components that could be in this home. Always consider hiring the appropriate expert for any repairs or further inspection.

**6.1 CEILINGS**

**6.2 WALLS**

**Comments:**

Due to stored personal items not all areas throughout the property were visible and accessible at the time of the inspection. The slab and other areas were obstructed from view and could not be inspected. The home inspector does not move personal items, panels, furniture, equipment, plant life, soil, debris, ect. that obstructs their access or visibility. We recommend that you conduct a careful evaluation during your final walk-through or prior to the end of your contingency period to ensure that there are no hidden defects. All doors, windows, and outlets should be tested and verified for proper operation prior to the end of your contingency period by a qualified person. If any damage is observed we recommend asking the seller about it. We recommend that any damage found be repaired or replaced by a qualified licensed contractor in the appropriate trade.

**6.3 FLOOR COVERINGS**

**6.4 STEPS, STAIRWAYS, RAILINGS**

**6.5 COUNTERS AND CABINETS (REPRESENTATIVE NUMBER)**

**Comments:**

---

IN NI NP RR IO Items

IN= Inspected, NI= Not Inspected, NP= Not Present, RR= Repair or Replace, IO= Information Only

IN NI NP RR IO Items

(1) Due to stored personal items such as towels, clothing, personal items, hygiene and/ or cleaning products, a full evaluation of the cabinets and closets could not be made. We recommend that you carefully inspect all cabinets and closets prior to the end of your contingency period or during your final walk through. The home inspector does not move personal items, panels, furniture, equipment, plant life, soil, debris, ect. that obstructs their access or visibility. If any damage is observed we recommend asking the seller about it. We recommend that any damage found be repaired or replaced by a qualified licensed contractor in the appropriate trade..



6.5 Item 1(Picture)

(2) Cabinet door hardware is noted to be loose at a kitchen cabinet doors. We recommend necessary corrections where needed by a qualified person.



6.5 Item 2(Picture)

**6.6 DOORS (REPRESENTATIVE NUMBER)**

**6.7 INFRARED CAMERA INSPECTION FINDINGS**  
**Comments:**

IN NI NP RR IO Items

IN= Inspected, NI= Not Inspected, NP= Not Present, RR= Repair or Replace, IO= Information Only

(1) Infrared Camera Thermal Photos.



6.7 Item 1(Picture)



6.7 Item 2(Picture)



6.7 Item 3(Picture)



6.7 Item 4(Picture)



6.7 Item 5(Picture)



6.7 Item 6(Picture)

(2) An infrared (thermal imaging) scan was performed throughout the property at the time of the inspection using a hand held infrared (thermal imaging) inspection camera. No anomalies were found at the time of the inspection using this camera.

IN NI NP RR IO Items

**6.8 SAFETY GLASS (INTERIOR)**

**Comments:**

The windows located with in the stairwell landing do not appear to have safety tempered glass as required. I could not find any markings on the glass which would confirm this safety feature. Having standard plate glass could cause serious injury if the glass breaks. While this may have been standard installation at the time of the original construction. We recommend upgrading the glass to tempered glass by a qualified licensed window contractor as a safety upgrade.



6.8 Item 1(Picture)

**6.9 INTERIORS - OTHER**

**Comments:**

- (1) Determining the presence of organic growths, moisture or wood rot behind any walls, floors and ceiling coverings is beyond the scope of our general home inspection. We recommend further evaluation by a qualified licensed contractor or a environmental hygienist prior to the end of your contingency if you are concerned.
- (2) MAINTENANCE RECOMMENDATION: We recommend re sealing (caulking or grouting) around all sink to counter top junctions and backsplash to countertop junctions, and around all bathroom shower pan(s), curb(s), tub/ shower floor junctions, and adjacent walls throughout the house or where needed by a qualified person to help prevent moisture intrusion in these areas.
- (3) MAINTENANCE RECOMMENDATION: We recommend having the property professionally cleaned prior to moving in by a licensed cleaning company.

IN NI NP RR IO Items

IN= Inspected, NI= Not Inspected, NP= Not Present, RR= Repair or Replace, IO= Information Only

The interior of the home was inspected and reported on with the above information. While the inspector makes every effort to find all areas of concern, some areas can go unnoticed. The inspection did not involve moving furniture and inspecting behind furniture, area rugs or areas obstructed from view. Please be aware that the inspector has your best interest in mind. Any repair items mentioned in this report should be considered before purchase. It is recommended that qualified licensed contractors be used in your further inspection or repair issues as it relates to the comments in this inspection report. Cosmetic deficiencies are considered normal wear and tear and are not reported.



## 7. Plumbing System



The home inspector shall observe: Interior water supply and distribution system, including: piping materials, supports, and insulation; fixtures and faucets; functional flow; leaks; and cross connections; Interior drain, waste, and vent system, including: traps; drain, waste, and vent piping; piping supports and pipe insulation; leaks; and functional drainage; Hot water systems including: water heating equipment; normal operating controls; automatic safety controls; and chimneys, flues, and vents; Fuel storage and distribution systems including: interior fuel storage equipment, supply piping, venting, and supports; leaks; and Sump pumps. The home inspector shall describe: Water supply and distribution piping materials; Drain, waste, and vent piping materials; Water heating equipment; and Location of main water supply shutoff device. The home inspector shall operate all plumbing fixtures, including their faucets and all exterior faucets attached to the house, except where the flow end of the faucet is connected to an appliance. The home inspector is not required to: State the effectiveness of anti-siphon devices; Determine whether water supply and waste disposal systems are public or private; Operate automatic safety controls; Operate any valve except water closet flush valves, fixture faucets, and hose faucets; Observe: Water conditioning systems; Fire and lawn sprinkler systems; On-site water supply quantity and quality; On-site waste disposal systems; Foundation irrigation systems; Spas, except as to functional flow and functional drainage; Swimming pools; Solar water heating equipment; or Observe the system for proper sizing, design, or use of proper materials unless otherwise agreed upon. Determining whether shower pans are watertight is beyond the scope of the inspection.

**Laundry Note:** Washers and dryers are not moved or tested during the inspection. The washer drain line and the dryer vent duct are not tested. Best practices for washer and dryer installation include the following recommendations: Use braided metallic water hoses to reduce the potential of leaks at the washing machine. Use flexible metal dryer vent connector. Use a half inch appliance connector and gas valve for all newer gas dryers. Installation of a drain pan under the washing machine with a drain pipe terminating at the exterior.

**Underground Gas Pipe Note:** Determining if the below ground gas pipes leak is beyond the scope of a home inspection. If concerned we recommend further evaluation of all underground gas piping by a licensed plumbing contractor prior to the end of your contingency period. Note: While the inspector attempts to discover gas leaks at the accessible gas fittings and appliances while using a gas leak detector, some leaks can go undetected.

**Home inspectors do not operate (turn) any water supply shut off valves at any property such as angle stops (the type under sinks and toilets), laundry hose spigots, water heater supply valves, or main water shut off valves at the meter. Home inspectors do not test clothes washer drains or stand pipes, or flood test the over-flow drains at tubs and sinks in accordance with industry standards of practice. If you have questions about these exclusions, please contact your home inspector.**

IN= Inspected, NI= Not Inspected, NP= Not Present, RR= Repair or Replace, IO= Information Only

**IN NI NP RR IO Items**

### 7.0 PLUMBING CONDO

**GAS DISTRIBUTION:** RIGID IRON PIPE, PARTIALLY VISIBLE

**Comments:**

This inspection is being conducted on a condominium unit. The inspection is limited to the components that are inside of the unit only. Plumbing components that are located beyond the interior of the condominium, such as common drain and supply pipes, are not evaluated as part of this inspection and are the responsibility of the HOA. If you have any concerns about any plumbing components outside the interior of this unit we recommend contacting the HOA.

### 7.1 DRAIN, WASTE, AND VENT SYSTEMS

**PLUMBING WASTE (OBSERVED INSIDE THE HOME):** ABS, PARTIALLY VISIBLE

**WASHER DRAIN SIZE:** 2" DIAMETER

**Comments:**

At the time of the inspection we evaluated all drain pipes by running water through every drain that has an active fixture while observing its draw and watching for blockages or slow draining. Kitchen and bathroom fixtures were tested for an extended period of time during the inspection. We did not test the laundry stand pipe if a washing

**IN NI NP RR IO Items**

IN= Inspected, NI= Not Inspected, NP= Not Present, RR= Repair or Replace, IO= Information Only

IN NI NP RR IO Items

machine is connected. A video-scan of the drains and main line can only help determine the actual condition(s) of these drain pipes. We recommend having a sewer camera inspection conducted to help determine the condition of the pipes prior to the end of your contingency period.

7.2 WATER SUPPLY, DISTRIBUTION SYSTEMS

WATER SOURCE: PUBLIC

PLUMBING WATER DISTRIBUTION (INSIDE THE HOME): COPPER, PARTIALLY VISIBLE, COPPER IN SLAB

Comments:

(1) It was common practice for homes to have some portions of the plumbing distribution system installed through the concrete slab which have been known to deteriorate and result in leaks. During the inspection, we tried to determine if any slab leaks may exist. At the time of the inspection, we scanned the slab using a thermal camera to help find any active leaks and there was no evidence of current/ active leaks observed or discovered.

(2) A corroded pipe is observed in the garage. We recommend further evaluation by a qualified licensed plumber and necessary repairs made.

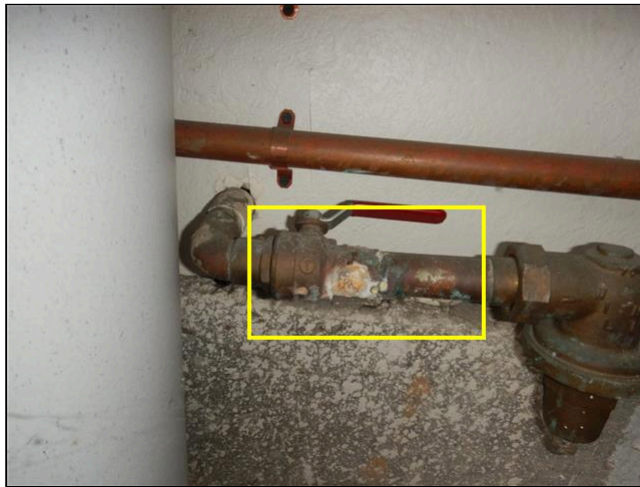

7.2 Item 1(Picture)

7.3 WATER PRESSURE/ REGULATOR

WATER PRESSURE (PSI): 95-100 PSI (HIGH)

Comments:

IN NI NP RR IO Items

IN= Inspected, NI= Not Inspected, NP= Not Present, RR= Repair or Replace, IO= Information Only

IN NI NP RR IO Items

The water pressure was checked with a water pressure gauge and was measured to be higher than 80 PSI at the time of the inspection. This is to high and corrections are needed. We recommend further evaluation by a qualified licensed plumber for necessary repairs or corrections.

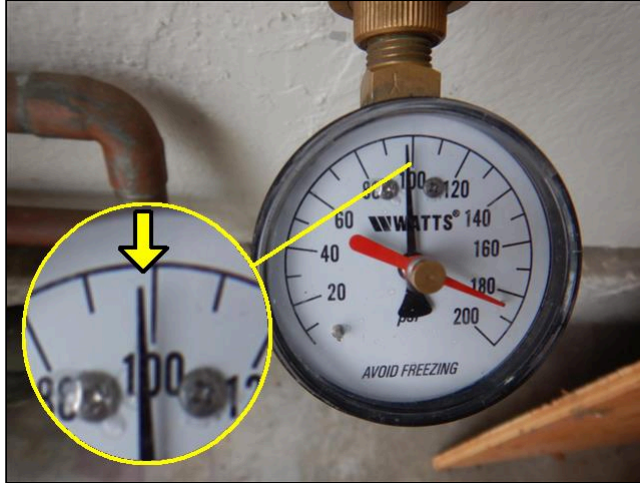

7.3 Item 1(Picture)

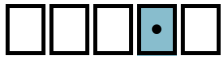

7.4 HOSE SPIGOT(S)

Comments:

(1) The accessible hose spigots were tested and were found to be operational at the time of the inspection. Note: Some hose spigots may leak or drip when a watering hose is connected due to back pressure.



7.4 Item 1(Picture)

IN NI NP RR IO Items

IN= Inspected, NI= Not Inspected, NP= Not Present, RR= Repair or Replace, IO= Information Only



IN NI NP RR IO Items

(2) The exterior hose spigots do not have anti-siphon or anti-backflow devices installed on them. These anti-siphon or anti-backflow devices help prevent contaminated water from flowing back into the the house water supply system. We recommend installing anti-siphon or anti-backflow devices at the every exterior hose spigots by a qualified person.



7.4 Item 2(Picture)

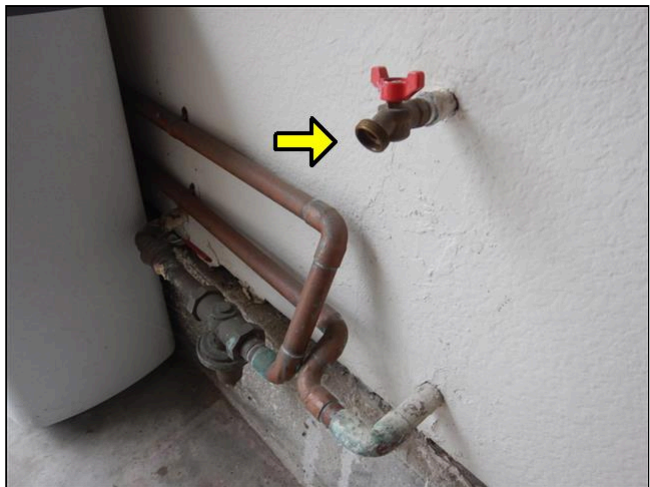

7.4 Item 3(Picture)

(3) The deck hose spigot is leaking when the water is turned on. We recommend necessary repairs or replacement by a qualified licensed plumber.



7.5 GAS/ FUEL STORAGE AND DISTRIBUTION SYSTEMS

Comments:

IN NI NP RR IO Items

IN= Inspected, NI= Not Inspected, NP= Not Present, RR= Repair or Replace, IO= Information Only

**IN NI NP RR IO Items**

---

A gas leak test was conducted at accessible gas fittings and appliances using a gas leak detector. There were no gas leaks detected at the time of the inspection.



7.5 Item 1(Picture)

---

**IN NI NP RR IO Items**

IN= Inspected, NI= Not Inspected, NP= Not Present, RR= Repair or Replace, IO= Information Only

---

The plumbing in the home was inspected and reported on with the above information. While the inspector makes every effort to find all areas of concern, some areas can go unnoticed. Washing machine drain line for example cannot be checked for leaks or the ability to handle the volume during drain cycle. The water supply and waste line piping that is concealed within inaccessible areas such as covered walls and concrete slab floors was not evaluated. Older homes with galvanized supply lines or cast iron drain lines can be obstructed and barely working during an inspection but then fails under heavy use. If the water is turned off or not used for periods of time (like a vacant home waiting for closing) rust or deposits within the pipes can further clog the piping system. Please be aware that the inspector has your best interest in mind. Any repair items mentioned in this report should be considered before purchase. It is recommended that qualified licensed contractors be used in your further inspection or repair issues as it relates to the comments in this inspection report.

**8(A) . Bathroom(s) / Hall Bathroom**

The bathroom(s) and it's related components were inspected and appeared to be functioning/ operating as intended at the time of the inspection unless other wise commented on in the appropriate bathroom section(s).



**MAINTENANCE RECOMMENDATION:** We recommend re sealing (caulking or grouting) around all sink to counter top junctions and backsplash to countertop junctions, and around all bathroom shower pan(s), curb(s), tub/ shower floor junctions, and adjacent walls throughout the house or where needed by a qualified person.

IN= Inspected, NI= Not Inspected, NP= Not Present, RR= Repair or Replace, IO= Information Only

**IN NI NP RR IO Items**

**8.0.A SINK(S)**

**Comments:**

The sink in the bathroom was slow draining at the time of the inspection This may indicate a blockage in the drain line. We recommend further evaluation by a qualified licensed plumber and repairs as needed.



8.0.A Item 1(Picture)

**8.1.A SHOWER**

**Comments:**

The shower head leaks when the water is running through it. We recommend replacement by a qualified person.

**8.2.A TUB**

**Comments:**

**IN NI NP RR IO Items**

IN= Inspected, NI= Not Inspected, NP= Not Present, RR= Repair or Replace, IO= Information Only

IN NI NP RR IO Items

(1) The tub diverter did not operate properly when tested. This is likely due from hard water deposit build up on the tub spout mechanism. We recommend necessary repairs or replacement by a licensed plumber.



8.2.A Item 1(Picture)

(2) The tub stopper is missing. We recommend replacing by a qualified person.



8.3.A BATHROOM OTHER

Comments:

MAINTENANCE RECOMMENDATION: We recommend re sealing (caulking or grouting) around all sink to counter top junctions and backsplash to countertop junctions, and around all bathroom shower pan(s), curb(s), tub/ shower floor junctions, and adjacent walls throughout the house or where needed by a qualified person to help prevent moisture intrusion in these areas.

IN NI NP RR IO Items

IN= Inspected, NI= Not Inspected, NP= Not Present, RR= Repair or Replace, IO= Information Only

The bathroom(s) were inspected and reported on with the above information. While the inspector makes every effort to find all areas of concern, some areas can go unnoticed. The inspection did not involve moving personal property, furniture and inspecting behind furniture, area rugs or areas obstructed from view. Please be aware that the inspector has your best interest in mind. Any repair items mentioned in this report should be considered before purchase. It is recommended that qualified licensed contractors be used in your further inspection or repair issues as it relates to the comments in this inspection report. Cosmetic deficiencies are considered normal wear and tear and are not reported.

**8(B) . Bathroom(s) / Master Bathroom**

The bathroom(s) and it's related components were inspected and appeared to be functioning/ operating as intended at the time of the inspection unless other wise commented on in the appropriate bathroom section(s).



**MAINTENANCE RECOMMENDATION:** We recommend re sealing (caulking or grouting) around all sink to counter top junctions and backsplash to countertop junctions, and around all bathroom shower pan(s), curb(s), tub/ shower floor junctions, and adjacent walls throughout the house or where needed by a qualified person.

IN= Inspected, NI= Not Inspected, NP= Not Present, RR= Repair or Replace, IO= Information Only

**IN NI NP RR IO Items**

**8.0.B SINK(S)**

**Comments:**

(1) The metal portions of the sink drain are rusted or corroded. A leak was not observed at this sink drain pipe at the time of the inspection. However, we recommend replacing this drain pipe by a qualified licensed plumber to help prevent future leaks or damage.



8.0.B Item 1(Picture)

(2) Some of the sink angle stop valves are observed with calcium deposits on them. Calcium deposits can corrode or deteriorate these valves and cause potential leaks. We recommend replacing all calcified angle stop valves by a qualified licensed plumber to help prevent leaks.

**8.1.B SHOWER**

**Comments:**

The shower head leaks when the water is running through it. We recommend replacement by a qualified person.

**8.2.B BATHROOM OTHER**

**Comments:**

**MAINTENANCE RECOMMENDATION:** We recommend re sealing (caulking or grouting) around all sink to counter top junctions and backsplash to countertop junctions, and around all bathroom shower pan(s), curb(s), tub/ shower floor junctions, and adjacent walls throughout the house or where needed by a qualified person to help prevent moisture intrusion in these areas.

**IN NI NP RR IO Items**

IN= Inspected, NI= Not Inspected, NP= Not Present, RR= Repair or Replace, IO= Information Only

The bathroom(s) were inspected and reported on with the above information. While the inspector makes every effort to find all areas of concern, some areas can go unnoticed. The inspection did not involve moving personal property, furniture and inspecting behind furniture, area rugs or areas obstructed from view. Please be aware that the inspector has your best interest in mind. Any repair items mentioned in this report should be considered before purchase. It is recommended that qualified licensed contractors be used in your further inspection or repair issues as it relates to the comments in this inspection report. Cosmetic deficiencies are considered normal wear and tear and are not reported.

## 9. Laundry

IN= Inspected, NI= Not Inspected, NP= Not Present, RR= Repair or Replace, IO= Information Only

**IN NI NP RR IO Items**

### 9.0 WASHING MACHINE/ DRYER CONNECTION(S)

**DRYER POWER SOURCE:** 220 VOLT ELECTRIC AND GAS, 220 VOLT ELECTRIC (3 PRONG)

**Comments:**

(1) There is a three prong 220 volt receptacle installed for the dryer. Most new electric dryers require a four prong receptacle. If you install an electric dryer, you may need to upgrade the receptacle or the dryer power cord. We recommend necessary corrections by a qualified licensed electrician.

(2) **MAINTENANCE RECOMMENDATION:** Washer hoses are a common source of flooding in a home. Prior to connecting the washing machine we recommend installing new braided steel washer hoses to help reduce leaks caused by failed hoses. If any hoses are left in the house they should be replaced. The washing machine and dryer are not part of our general home inspection.

(3) The hot and cold laundry water shut off valves are older gate valves. These gate valves can become "seized" due to lack of regular use and/ or calcium build up. Home inspectors do not test these valves as they may leak if turned. We recommend replacing these gate valves with ball type water shut off valves by a qualified licensed plumber.



9.0 Item 1(Picture)

### 9.1 CLOTHES DRYER VENT

**DRYER VENT:** FLEXIBLE METAL, METAL

**Comments:**

**IN NI NP RR IO Items**

IN= Inspected, NI= Not Inspected, NP= Not Present, RR= Repair or Replace, IO= Information Only

IN NI NP RR IO Items

We recommend having the dryer vent cleaned by a qualified person.



9.1 Item 1(Picture)



9.2 LAUNDRY OTHER

Comments:

The clothes washer and dryer are not part of our general inspection and were not inspected or commented on. If concerned about there serviceability and functionality we recommend further evaluation by a qualified licensed appliance contractor prior to the end of your contingency period.

IN NI NP RR IO Items

IN= Inspected, NI= Not Inspected, NP= Not Present, RR= Repair or Replace, IO= Information Only

The laundry room/ area inspected and reported on with the above information. While the inspector makes every effort to find all areas of concern, some areas can go unnoticed. The inspection did not involve moving personal property, furniture, washing machine/ dryer and inspecting behind furniture, area rugs or areas obstructed from view. Please be aware that the inspector has your best interest in mind. Any repair items mentioned in this report should be considered before purchase. It is recommended that qualified licensed contractors be used in your further inspection or repair issues as it relates to the comments in this inspection report. Cosmetic deficiencies are considered normal wear and tear and are not reported.



## 10. Fireplaces/ Chimneys

This inspection of the fireplace/ chimney is limited to the readily visible portions only. The inner reaches of a chimney flue are not visually accessible and the view from the top or bottom is not adequate to discover possible deficiencies or damage with in our general home inspection. We recommend that a National Fire Protection Association (NFPA) 211 Standard, Level II inspection by a qualified licensed professional be preformed prior to the end of your contingency period. They can use specialized tools, testing procedures, mirrors, and video cameras to thoroughly evaluate the fireplace system. We do not light the gas or start a fire, or check for proper drafting.

We recommend that all fireplaces be cleaned and inspected by a qualified licensed person prior to using and on a regular basis to insure safe operation.

IN= Inspected, NI= Not Inspected, NP= Not Present, RR= Repair or Replace, IO= Information Only

**IN NI NP RR IO Items**

**10.0 CHIMNEY(S)**

**FIRE PLACE TYPES:** FACTORY BUILT, CONCRETE LOG KIT

**NUMBER OF FIREPLACE(S):** ONE

**Comments:**

We recommend having the fireplace and chimney cleaned and inspected by a licensed chimney sweep for safety prior to using.

**10.1 FIREPLACE(S)**

**10.2 DAMPER/ DAMPER CLAMP**

**Comments:**

**IN NI NP RR IO Items**

IN= Inspected, NI= Not Inspected, NP= Not Present, RR= Repair or Replace, IO= Information Only

IN NI NP RR IO Items

A damper clamp is not installed at the family room fireplace damper door. A damper clamp is required to be installed at a damper door when there is a gas supply to the fireplace(s). This damper clamp help prevents the damper from closing all the way as a safety precaution. If the damper is closed, Carbon Monoxide gas could enter the living space easier which is undetectable. SDG&E now requires damper clamps at all fireplaces damper doors. We recommend installation of a damper clamp by a qualified person.



10.2 Item 1(Picture)



10.2 Item 2(Picture)



10.3 HEARTH/ MANTLE

Comments:

IN NI NP RR IO Items

IN= Inspected, NI= Not Inspected, NP= Not Present, RR= Repair or Replace, IO= Information Only

IN NI NP RR IO Items

The hearth at the front of the fireplace is missing/ of inadequate size/ or an improper material. This condition does not comply with current building and fire and safety requirements. We recommend installation of a properly sized hearth by a qualified licensed contractor.

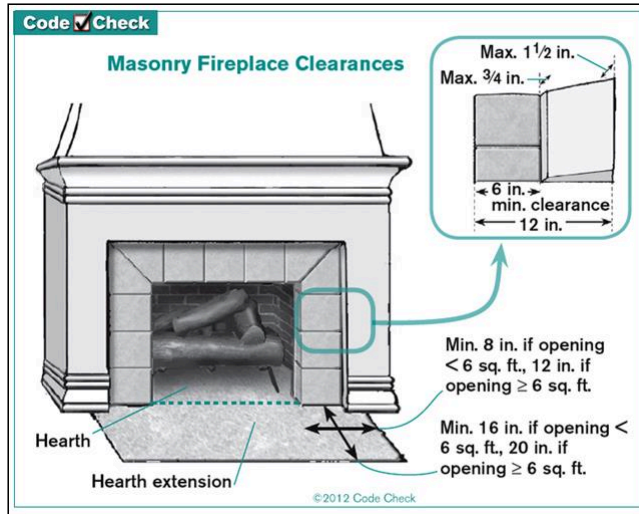

10.3 Item 1(Picture)



10.3 Item 2(Picture)

• □ □ □ □ **10.4 OPERATING CONTROLS**

**Comments:**

We do not light gas log lighters or concrete log kits installed at the fireplace. This is beyond the scope of the home inspection. However, the fireplace gas valve was tested and gas was noted to come out of the fireplace gas pipe.

IN NI NP RR IO Items

IN= Inspected, NI= Not Inspected, NP= Not Present, RR= Repair or Replace, IO= Information Only

The fireplace was inspected and reported on with the above information. While the inspector makes every effort to find all areas of concern, some areas can go unnoticed. Please be aware that the inspector has your best interest in mind. Any repair items mentioned in this report should be considered before purchase. It is recommended that qualified licensed contractors be used in your further inspection or repair issues as it relates to the comments in this inspection report.

# 11. Detectors, Safety, Security



IN= Inspected, NI= Not Inspected, NP= Not Present, RR= Repair or Replace, IO= Information Only

**IN NI NP RR IO Items**

**11.0 SMOKE DETECTORS**

**Comments:**

(1) We recommend installing additional smoke detectors where needed to comply with current fire and safety standards and regulations as a safety upgrade.

(2) The smoke detectors in the property are older. Studies show that detectors that are more than 10 years old have a high rate of failure. Many old detectors do not have battery back-up, and will not work if the electricity is off. We recommend that all old detectors be replaced prior to occupancy of the house for safety.



11.0 Item 1(Picture)

**11.1 CARBON MONOXIDE DETECTOR(S)**

**Comments:**

**IN NI NP RR IO Items**

IN= Inspected, NI= Not Inspected, NP= Not Present, RR= Repair or Replace, IO= Information Only

(1) **Photo of carbon monoxide detector(s).**



11.1 Item 1(Picture)

(2) The quantity of Carbon Monoxide detectors that are required to be installed varies with each house. Larger houses, or those with multiple levels are required to have more CO detectors. A Carbon Monoxide detector is required on each level of a multi-level house and adjacent to each cluster of bedrooms. We recommend installing additional Carbon Monoxide detectors where needed.



**11.2 SAFETY - OTHER**

**Comments:**

- (1) All smoke detector should be tested upon moving into home, and every six months or per manufactures instructions. Smoke detectors should be replaced when they reach 10 years of age as their sensor becomes less effective over time or per manufactures instructions.
- (2) All carbon monoxide detectors should be tested upon moving into home, and every six months or per manufactures instructions. Carbon monoxide detectors should be replaced per manufactures instructions.

## 12. Heating Equipment

The home inspector shall observe permanently installed heating and cooling systems including: Heating equipment; Cooling Equipment that is central to home; Normal operating controls; Automatic safety controls; Chimneys, flues, and vents, where readily visible; Solid fuel heating devices; Heat distribution systems including fans, pumps, ducts and piping, with supports, insulation, air filters, registers, radiators, fan coil units, convectors; and the presence of an installed heat source in each room. The home inspector shall describe: Energy source; and Heating equipment and distribution type. The home inspector shall operate the systems using normal operating controls. The home inspector shall open readily openable access panels provided by the manufacturer or installer for routine homeowner maintenance. The home inspector is not required to: Operate heating systems when weather conditions or other circumstances may cause equipment damage; Operate automatic safety controls; Ignite or extinguish solid fuel fires; or Observe: The interior of flues: the interior of ducts; Fireplace insert flue connections; Humidifiers; Electronic air filters; or The uniformity or adequacy of heat supply to the various rooms.



Note: A limited visual inspection can not adequately evaluate the heat exchanger for cracks and holes. Most areas of the heat exchanger are not visible without dismantling the furnace. Dismantling the furnace is beyond the scope of our general home inspection. Evaluation of the heat exchanger is expressly excluded. Evaluating the adequacy, efficiency, or even distribution of air throughout the home is not part of the inspection. Thermostats are not checked for calibration or programmable features, interior of the ducts are not inspected for cleanliness and if concerned about the cleanliness we recommend having them checked and cleaned by a licensed HVAC contractor prior to the end of your contingency period.

IN= Inspected, NI= Not Inspected, NP= Not Present, RR= Repair or Replace, IO= Information Only

**IN NI NP RR IO Items**

**12.0 HEATING EQUIPMENT**

**HEAT TYPE:** FORCED AIR

**NUMBER OF HEAT SYSTEMS (EXCLUDING WOOD):** ONE

**ENERGY SOURCE:** NATURAL GAS

**AGE OF HEATER:** GAS - OVER 20 YEARS OLD

**Comments:**

(1) **Infrared Thermal photo of the furnace(s) being tested.**



12.0 Item 1(Picture)

**IN NI NP RR IO Items**

IN= Inspected, NI= Not Inspected, NP= Not Present, RR= Repair or Replace, IO= Information Only



12.0 Item 2(Picture)

(2) The furnace is older but did work at the time of the inspection. I was unable to determine life remaining. Most HVAC contractors state that furnaces that are 20 years old or older are more likely be at the end of their useful life. We therefore recommend that you have this furnace inspected and serviced by a qualified licensed HVAC contractor to make sure that it is safe, and to obtain an estimate of life remaining, and a cost of replacement prior to the end of your contingency period. We also recommend that you keep a good home warranty in place, which covers the furnace.



12.0 Item 3(Picture)





12.0 Item 4(Picture)

(3) The gas supply pipe at the furnace did not contain a drip leg/ sediment trap. This may have been standard at the time of installation but now is highly recommended. The purpose of a drip leg is to help prevent sediment/ debris from entering and clogging the furnace gas valve which could cause the furnace to shut down. We recommend having a drip leg installed by a qualified licensed HVAC contractor.

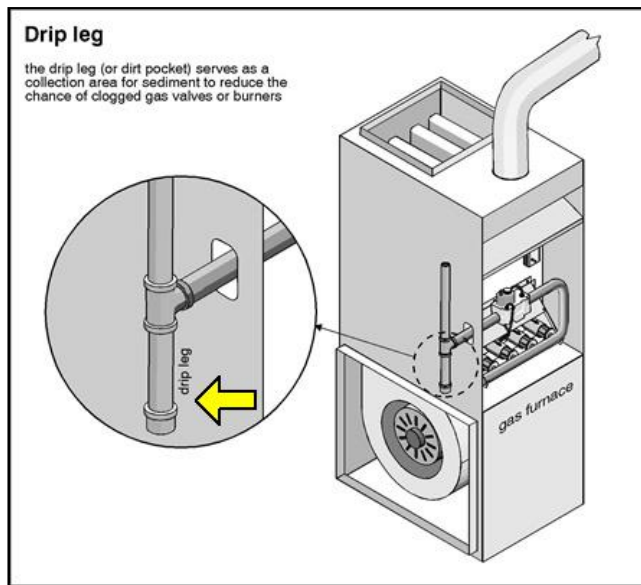

12.0 Item 5(Picture)



12.0 Item 6(Picture)

(4) The flexible gas supply pipe passes through the furnace housing. Vibration from the furnace can wear through flexible gas pipe which could cause a gas leak. SDG&E is "Red Tagging" this condition as they considered it to be unsafe. Due to this condition we recommend a rigid cast pipe be installed from the gas regulator through furnace housing, to the exterior of furnace housing by a qualified licensed HVAC contractor.



**12.1 THERMOSTAT(S)**

**Comments:**

- (1) The thermostat was operational when used to operate the HVAC system at the time of the inspection. Programmable thermostats are not adjusted and no testing is done to check the accuracy or programmed settings of the thermostat. If concerned we recommend verifying proper operation of the programmable settings prior to the end of your contingency period by a qualified person.
- (2) The the thermostat batteries are weak or dead. We recommend replacement by a qualified person.



12.1 Item 1(Picture)



**12.2 VENTS AND FLUES (HEATING SYSTEM)**

IN NI NP RR IO Items



**12.3 DISTRIBUTION SYSTEMS (INCLUDING FANS, PUMPS, DUCTS, INSULATION, FILTERS, REGISTERS)**

**DUCTWORK:** INSULATED

**FILTER TYPE:** FILTER(S) ARE DIRTY. WE RECOMMEND REPLACING.

**Comments:**

The air filter(s) for the HVAC system is dirty. We recommend recommend replacing by a qualified person.

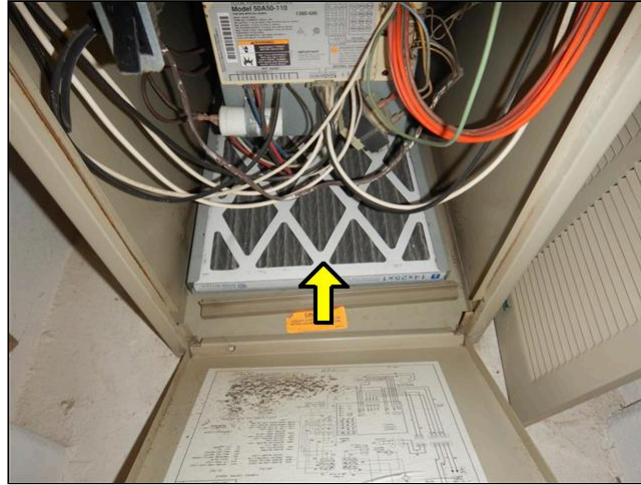

12.3 Item 1(Picture)

IN NI NP RR IO Items

IN= Inspected, NI= Not Inspected, NP= Not Present, RR= Repair or Replace, IO= Information Only

The heating and cooling system of this home was inspected and reported on with the above information. While the inspector makes every effort to find all areas of concern, some areas can go unnoticed. The inspection is not meant to be technically exhaustive. The inspection does not involve removal and inspection behind service door or dismantling that would otherwise reveal something only a licensed heat contractor would discover. Please be aware that the inspector has your best interest in mind. Any repair items mentioned in this report should be considered before purchase. It is recommended that qualified licensed contractors be used in your further inspection or repair issues as it relates to the comments in this inspection report.

## 13. Cooling Equipment

The home inspector shall observe: Central air conditioning and permanently installed cooling systems including: Cooling and air handling equipment; and Normal operating controls. Distribution systems including: Fans, pumps, ducts and piping, with associated supports, dampers, insulation, air filters, registers, fan-coil units; and The presence of an installed cooling source in each room. The home inspector shall describe: Energy sources; and Cooling equipment type. The home inspector shall operate the systems using normal operating controls. The home inspector shall open readily openable access panels provided by the manufacturer or installer for routine homeowner maintenance The home inspector is not required to: Observe window air conditioners or operate cooling systems when weather conditions or other circumstances may cause equipment damage; Observe non-central air conditioners; or Observe the uniformity or adequacy of cool-air supply to the various rooms.



IN= Inspected, NI= Not Inspected, NP= Not Present, RR= Repair or Replace, IO= Information Only

**IN NI NP RR IO Items**

**13.0 COOLING EQUIPMENT**

**COOLING EQUIPMENT TYPE:** AIR CONDITIONER, R-22

**NUMBER OF A/C UNITS:** ONE

**CONDENSER AGE:** 15 PLUS YEARS OLD

**Comments:**

- (1) **Photo of the A/C unit(s).**



13.0 Item 1(Picture)

**IN NI NP RR IO Items**

IN= Inspected, NI= Not Inspected, NP= Not Present, RR= Repair or Replace, IO= Information Only

IN NI NP RR IO Items

(2) The air conditioning system in this property is an older system which may have R 22 freon. Effective January 1, 2020 the Department of Energy mandates that all manufactured air conditioner condensing units use R 410-A freon. The older R 22 freon will no longer be allowed. We recommend further evaluation by a licensed HVAC contractor prior to the end of your contingency period to check the freon level and for upgrade or replacement options. If the repair requires adding R22 refrigerant to the system, the only options will be reclaimed and previously-produced R22 refrigerant. Once there is no more R22 refrigerant available the compressor must be replaced. We also recommend budgeting for replacement and obtaining and keeping a Home Warranty that covers this HVAC system.

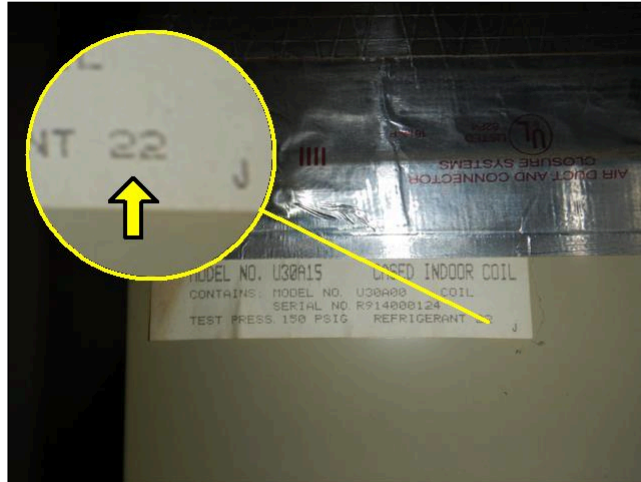

13.0 Item 2(Picture)

(3) The AC system is 15 or more years old and may be near the end of its useful life. The average life of an AC system is approximately 10-15 years. We recommend further evaluation and servicing by a qualified licensed HVAC contractor to determine life remaining and potential cost to replace so that you can budget accordingly. We also recommend that you keep a good home warranty in place, which covers the AC system.

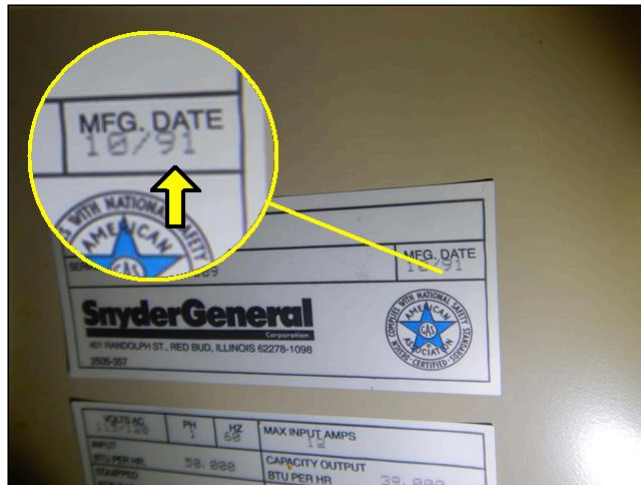

13.0 Item 3(Picture)

IN NI NP RR IO Items

IN= Inspected, NI= Not Inspected, NP= Not Present, RR= Repair or Replace, IO= Information Only



IN NI NP RR IO Items

(4) An ambient air test was performed by using a thermal camera on the AC system to determine if the difference in temperatures of the supply and return air were between 14 degrees and 22 degrees which indicates that the AC system is cooling as intended.

The air supplied to the room was measured around **38 degrees**.

The air returning to the system (return) was measured at **57 degrees**.

This indicates that the range in temperature drop is normal. This is not an exhaustive test and cannot predict the performance of the AC systems on extremely hot or humid days.

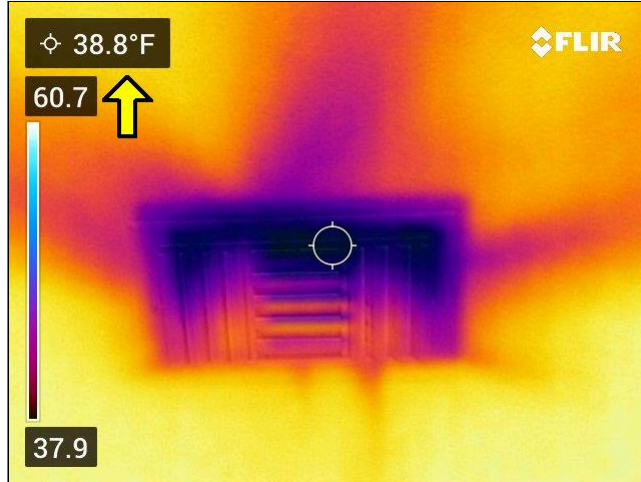

13.0 Item 4(Picture)



13.0 Item 5(Picture)

IN NI NP RR IO Items

IN= Inspected, NI= Not Inspected, NP= Not Present, RR= Repair or Replace, IO= Information Only

IN NI NP RR IO Items

(5) The insulation is missing at the exterior refrigerant lines. We recommend replacing the missing insulation by a qualified person.

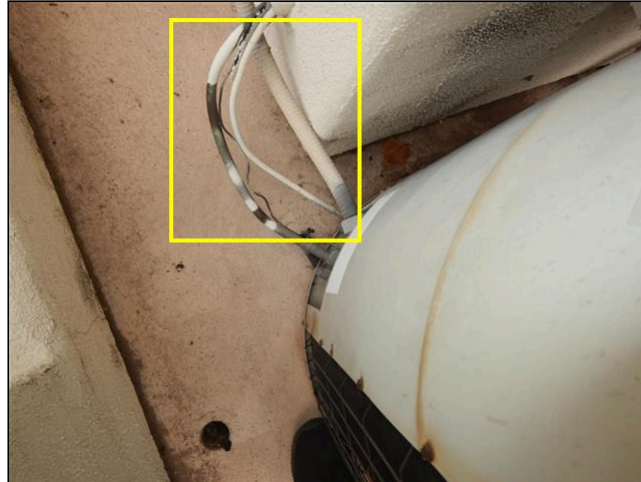

13.0 Item 6(Picture)



**13.1 CONDENSATE EQUIPMENT**

**Comments:**

A vented trap was not installed in the condensation drain line. A vented trap must be installed in the condensation drain line to prevent vapor lock and possible condensation leaks in the house. We recommend installation of a vented trap by a qualified licensed HVAC contractor.

IN NI NP RR IO Items

IN= Inspected, NI= Not Inspected, NP= Not Present, RR= Repair or Replace, IO= Information Only

The cooling system of this home was inspected and reported on with the above information. While the inspector makes every effort to find all areas of concern, some areas can go unnoticed. The inspection is not meant to be technically exhaustive. The inspection does not involve removal and inspection behind service door or dismantling that would otherwise reveal something only a licensed HVAC contractor would discover (Heating, Ventilation, and Air Conditioning). Please be aware that the inspector has your best interest in mind. Any repair items mentioned in this report should be considered before purchase. It is recommended that qualified licensed contractors be used in your further inspection or repair issues as it relates to the comments in this inspection report.



## 14. Ventilation and Insulation

The home inspector shall observe: Insulation and vapor retarders in unfinished spaces; Ventilation of attics and foundation areas; Kitchen, bathroom, and laundry venting systems; and the operation of any readily accessible attic ventilation fan, and, when temperature permits, the operation of any readily accessible thermostatic control. The home inspector shall describe: Insulation in unfinished spaces; and Absence of insulation in unfinished space at conditioned surfaces. The home inspector shall: Move insulation where readily visible evidence indicates the need to do so; and Move insulation where chimneys penetrate roofs, where plumbing drain/waste pipes penetrate floors, adjacent to earth filled stoops or porches, and at exterior doors. The home inspector is not required to report on: Concealed insulation and vapor retarders; or Venting equipment that is integral with household appliances.



IN= Inspected, NI= Not Inspected, NP= Not Present, RR= Repair or Replace, IO= Information Only

### IN NI NP RR IO Items

### IN NI NP RR IO Items

IN= Inspected, NI= Not Inspected, NP= Not Present, RR= Repair or Replace, IO= Information Only

The insulation and ventilation of the home was inspected and reported on with the above information. While the inspector makes every effort to find all areas of concern, some areas can go unnoticed. Venting of exhaust fans or clothes dryer cannot be fully inspected and bends or obstructions can occur without being accessible or visible (behind wall and ceiling coverings). Only insulation that is visible was inspected. Please be aware that the inspector has your best interest in mind. Any repair items mentioned in this report should be considered before purchase. It is recommended that qualified licensed contractors be used in your further inspection or repair issues as it relates to the comments in this inspection report.

## 15. Structural Components

The Home Inspector shall observe structural components including foundations, floors, walls, columns or piers, ceilings and roof. The home inspector shall describe the type of Foundation, floor structure, wall structure, columns or piers, ceiling structure, roof structure. The home inspector shall: Probe structural components where deterioration is suspected; Enter under floor crawl spaces, basements, and attic spaces except when access is obstructed, when entry could damage the property, or when dangerous or adverse situations are suspected; Report the methods used to observe under floor crawl spaces and attics; and Report signs of abnormal or harmful water penetration into the building or signs of abnormal or harmful condensation on building components. The home inspector is not required to: Enter any area or perform any procedure that may damage the property or its components or be dangerous to or adversely effect the health of the home inspector or other persons.



Note: Much of the home structure is hidden behind exterior and interior roof, floor, wall, and ceiling coverings, or is buried underground. Because the General Home Inspection is limited to visual and non-invasive methods, this report may not identify all structural deficiencies. Identification of portions of the wall structure not directly visible requires logical assumptions on the part of the Inspector that are based on the Inspectors past experience and knowledge of common building practices.

Upon observing indications that structural problems may exist that are not readily visible, or the evaluation of which lies beyond the Inspector's expertise, the inspector may recommend evaluation or testing by a specialist that may include invasive measures, which would require homeowner permission.

IN= Inspected, NI= Not Inspected, NP= Not Present, RR= Repair or Replace, IO= Information Only

**IN NI NP RR IO Items**

**15.0 STRUCTURE (CONDO)**

**Comments:**

This inspection was performed on a Condo. It includes the interior of the unit only. It specifically excludes any crawlspaces, if present. A condo inspection specifically excludes an evaluation of the wood, structure, or foundation.

**15.1 SLAB**

**1ST LEVEL FLOOR STRUCTURE: SLAB - OLD**

**Comments:**

- (1) The concrete slab throughout the property was not visible to inspect. Home Inspectors do not move stored items or lift floor coverings which may conceal cracks or other concealed defects that the inspector cannot see. This should not deter you from further evaluation by a qualified licensed foundation contractor or structural engineer prior to the end of your contingency period if concerned about the slab. It would be your (clients) responsibility to arrange this and for lifting or removing of the flooring.
- (2) Concrete slabs are prone to cracking. Home Inspectors do not move stored items or lift floor coverings which may conceal cracks that the inspector cannot see. This should not deter you from further evaluation by a qualified licensed foundation contractor or structural engineer if concerned about the slab. It would be your (clients) responsibility to arrange this and for lifting or removing of the flooring.

**IN NI NP RR IO Items**

IN= Inspected, NI= Not Inspected, NP= Not Present, RR= Repair or Replace, IO= Information Only

The structure of the home was inspected and reported on with the above information. While the inspector makes every effort to find all areas of concern, some areas can go unnoticed. Please be aware that the inspector has your best interest in mind. Any repair items mentioned in this report should be considered before purchase. It is recommended that qualified licensed contractors be used in your further inspection or repair issues as it relates to the comments in this inspection report.

## 16. Built-In Kitchen Appliances

The home inspector shall observe and operate the basic functions of the following kitchen appliances: Permanently installed dishwasher, through its normal cycle; Range, cook top, and permanently installed oven; Trash compactor; Garbage disposal; Ventilation equipment or range hood; and Permanently installed microwave oven. Inspection of built-in appliances is limited. It does not include dismantling and inspection of internal parts. The home inspector is not required to observe: Clocks, timers, self-cleaning oven function, or thermostats for calibration or automatic operation; Non built-in appliances; or Refrigeration units. The home inspector is not required to operate: Appliances in use; or Any appliance that is shut down or otherwise inoperable, or determine the effectiveness or life remaining of any built-in appliances.



IN= Inspected, NI= Not Inspected, NP= Not Present, RR= Repair or Replace, IO= Information Only

**IN NI NP RR IO Items**

### 16.0 DISHWASHER

**Comments:**

**Infrared Thermal photo of the dishwasher being tested.**

The dishwasher was tested and functioned properly at the time of the inspection. This is not an exhaustive test and does not verify the cleaning efficiency of the dishwasher.



16.0 Item 1(Picture)



16.0 Item 2(Picture)

**IN NI NP RR IO Items**

IN= Inspected, NI= Not Inspected, NP= Not Present, RR= Repair or Replace, IO= Information Only

IN NI NP RR IO Items

**16.1 FOOD WASTE DISPOSER**

**Comments:**

- (1) The food waste disposer was tested and functioned properly at the time of the inspection. This is not an exhaustive test and does not verify the efficiency of the unit.
- (2) The food waste disposal drain is installed in a non-standard manner. The drain tube exiting the disposer is installed horizontally and intersects the drain line of the other sink basin with a "T" fitting, then down to the P-trap. This can cause waste from the disposer to rise into the opposite sink basin before draining. We recommend necessary corrections by a qualified licensed plumber.

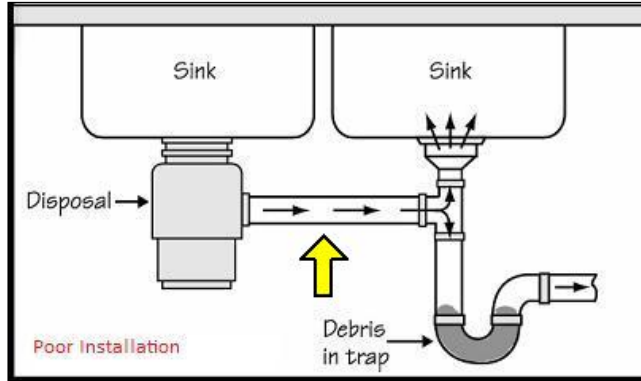

16.1 Item 1(Picture)



16.1 Item 2(Picture)

**16.2 RANGE HOOD/ VENT**

RANGE HOOD/ EXHAUST TYPE: VENTED

**Comments:**

IN NI NP RR IO Items

IN= Inspected, NI= Not Inspected, NP= Not Present, RR= Repair or Replace, IO= Information Only

IN NI NP RR IO Items

The range exhaust vent was tested and was functional at the time of the the inspection. This is not an exhaustive test, and does not evaluate the performance or effectiveness of the unit.

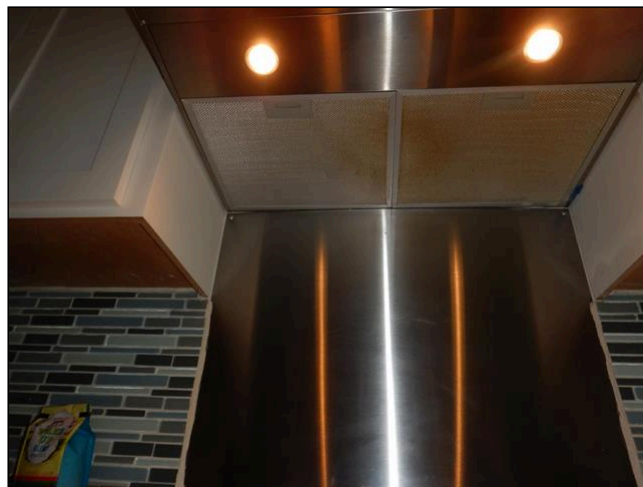

16.2 Item 1(Picture)



16.3 COOKTOP

Comments:

The cooktop was tested and was functional at the time of the inspection. This test is not exhaustive and does not confirm the performance, accuracy, or effectiveness of the cooktop.



16.3 Item 1(Picture)



16.4 WALL OVEN

Comments:

IN NI NP RR IO Items

IN= Inspected, NI= Not Inspected, NP= Not Present, RR= Repair or Replace, IO= Information Only

IN NI NP RR IO Items

The wall oven was tested and was functional at the time of the inspection. This test is not exhaustive and does not confirm the performance, accuracy, or effectiveness of the wall oven.

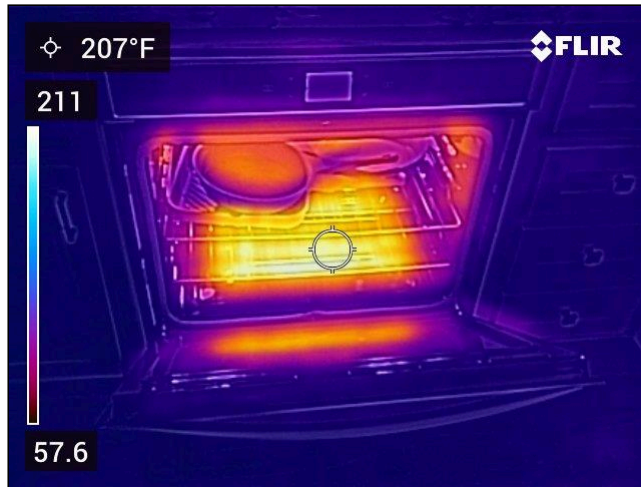

16.4 Item 1(Picture)



**16.5 REFRIGERATOR**

**Comments:**

(1) Refrigerators built in or not are not part of our general home inspection and are not inspected or commented on. If concerned about its serviceability and functionality we recommend further evaluation by a qualified licensed appliance contractor prior to the end of your contingency period.

(2) I could not identify or inspect the outlet or water shut off valve for the refrigerator. I do not move refrigerators in order to access the outlet or water shut off valve. Moving refrigerators is out of the scope of a home inspection are not moved to inspect the walls/floors/other components behind them. If concerned we recommend verifying that the outlet and water shut off valve is operational, not corroded and not leaking prior to the end of your contingency period.

IN NI NP RR IO Items

IN= Inspected, NI= Not Inspected, NP= Not Present, RR= Repair or Replace, IO= Information Only

The built-in appliances of the home were inspected and reported on with the above information. While the inspector makes every effort to find all areas of concern, some areas can go unnoticed. Please be aware that the inspector has your best interest in mind. Any repair items mentioned in this report should be considered before purchase. It is recommended that qualified licensed contractors be used in your further inspection or repair issues as it relates to the comments in this inspection report.



## 17. Gas, Electric, Water Shut-Off Locations

Home inspectors do not operate (turn) the main water supply shut off valve or the main gas shut off valve in accordance with industry standards of practice. If you are concerned about the functionality of these valves we recommend contacting a licensed plumber prior to the end of your contingency period for review. If you have questions about these exclusions, please contact your home inspector.

IN= Inspected, NI= Not Inspected, NP= Not Present, RR= Repair or Replace, IO= Information Only

**IN NI NP RR IO Items**

**17.0 MAIN GAS SHUT-OFF VALVE**

**Comments:**

The main gas shut off valve is located at the gas meter at the right exterior side of the property (facing front).



17.0 Item 1(Picture)

**17.1 MAIN WATER SHUT-OFF**

**Comments:**

The main water shut off valve is located in the garage.



17.1 Item 1(Picture)

**IN NI NP RR IO Items**

IN= Inspected, NI= Not Inspected, NP= Not Present, RR= Repair or Replace, IO= Information Only



IN NI NP RR IO Items

---

17.2 SUB ELECTRICAL PANEL(S)

**Comments:**

The sub-panel is located in the garage.



17.2 Item 1(Picture)

---

IN NI NP RR IO Items

IN= Inspected, NI= Not Inspected, NP= Not Present, RR= Repair or Replace, IO= Information Only

## General Summary



### The Property Inspection Pros

**www.tpips.com**  
**jduncan@tpips.com**  
**Cell - 760-525-5340**  
**Certified Master Inspector**

**Customer**  
Rick Smyth

**Address**  
1243 Main Lane  
San Diego CA 92128

The following items or discoveries indicate that these systems or components **do not function as intended** or **adversely affects the habitability of the dwelling**; or **warrants further investigation by a specialist**, or **requires subsequent observation**. This summary shall not contain recommendations for routine upkeep of a system or component to keep it in proper functioning condition or recommendations to upgrade or enhance the function or efficiency of the home. This Summary is not the entire report. The complete report may include additional information of concern to the customer. It is recommended that the customer read the complete report.

## 2. Exterior

### 2.2 DOORS (EXTERIOR)

#### Repair or Replace

- (1) The door has a torn or damaged screen. We recommend repair or replacement by a qualified person.
- (2) The deck door weather-stripping is damaged. We recommend replacement by a qualified person.

## 3. Electrical System

### 3.9 OPERATION OF GFCI (GROUND FAULT CIRCUIT INTERRUPTERS)

#### Inspected

- (2) We recommend upgrading all receptacles within 6 feet of any plumbing fixtures, outside/ exterior, in the garage, and any non fixed appliance receptacles in the kitchen to GFCI protected receptacles by a qualified licensed electrician for safety.

## 4. Garage

### 4.1 GARAGE VEHICLE DOOR OPENER(S)

#### Repair or Replace

(1) Due to the high number of garage door openers that fail to auto-reverse when testing the garage door openers pressure-activated auto-reverse feature which could cause severe damage to the garage door and its related components when it fails to auto-reverse, we did not test the garage door openers pressure-activated auto-reverse feature at the time of the inspection. We recommend having the garage door(s) pressure-activated auto-reverse feature tested prior to the end of your contingency period by a qualified licensed garage door contractor.

(3) The garage door push-button switch is lower than the recommended 5-foot minimum height above the standing surface. This condition is potentially dangerous to children. We recommend that the switch be raised to the 5-foot minimum or higher by a qualified licensed garage door contractor for safety reasons.

### 4.2 GARAGE CEILING

#### Inspected

The ceiling has typical cosmetic wear. You may wish to view this for yourself and have necessary repairs made by a qualified person.

### 4.3 GARAGE WALLS (INCLUDING FIREWALL SEPERATION)

#### Inspected

(1) Due to occupants personal items, not all areas of the property were visible and accessible at the time of the inspection. Several windows, doors, outlets, walls, flooring, and other areas were obstructed from view and could not be inspected. The home inspector does not move personal items, panels, furniture, equipment, plant life, soil, debris, ect. that obstructs their access or visibility. We recommend that you conduct a careful evaluation during your final walk-through or prior to the end of your contingency period to ensure that there are no hidden defects. All doors, windows, and outlets should be tested and verified for proper operation prior to the end of your contingency period by a qualified person. If any damage is observed we recommend asking the seller about it. We recommend that any damage found be repaired or replaced by a qualified licensed contractor in the appropriate trade.

### 4.5 FIRE-RATED DOOR

#### Inspected

The door between the house and garage did not have a Fire Rating Certificate or Plate. Without a plate, I could not confirm whether the door meets fire code safety requirements. We recommend further evaluation by a licensed door contractor. The "fire door" is required to meet one of the following characteristics: 1-3/8 inch thick solid wood, 1-3/8 inch thick steel shell door with Honeycomb core, Fire-rated (with certificate plate). If the door is not rated as a fire door we recommend replacing by a qualified licensed door contractor for safety.

### 4.7 OUTLETS/ FIXTURES/ WIRING/ 220V

#### Repair or Replace

There is an extension cord being used as wiring at the garage door opener. This is a non standard installation. We recommend having a permanent receptacle installed for use by the garage door opener by a qualified licensed electrician.

## 5. Water Heater

### 5.0 MAIN WATER HEATER (CONTROLS)

#### Repair or Replace

(2) **Thermal Photo of the water temperature.**

The temperature of the water was tested using a thermal camera at the time of the inspection and found to be above 125 degrees. Water temperatures above 125 degrees can cause scalding or burns.

Most water heater manufacturers recommend setting the water heater controls at 120 degrees for optimum efficiency. We recommend setting the water heater controls at 120 degrees by a qualified person for optimum efficiency.

## 6. Interiors

### 6.0 INTERIORS (GENERAL COMMENTS)

#### Inspected

(4) **We did not test the property for asbestos. Testing for asbestos is out of the scope of a general home inspection and was not done by this company at the time of the inspection. If your concerned that the this property may contain asbestos, we recommend that you have the property tested for asbestos prior to the end of your contingency period by a qualified licensed contractor.**

(5) This home is older and the home inspector considers this while inspecting. It is common to have areas that no longer comply with current code. This is not a new home and this home cannot be expected to meet current code standards. While this inspection makes every effort to point out safety issues, it does not inspect for code. It is common that homes of any age will have had repairs performed and some repairs may not be in a workmanlike manner. Some areas may appear less than standard. This inspection looks for items that are not functioning as intended. It does not grade the repair. It is common to see old plumbing or mixed materials. Sometimes water signs in crawlspaces or basements could be years old from a problem that no longer exists. Or, it may still need further attention and repair. Determining this can be difficult on an older home. Sometimes in older homes there are signs of damage to wood from wood eating insects. Having this is typical and fairly common. If the home inspection reveals signs of damage you should have a pest control company inspect further for activity and possible hidden damage. The home inspection does not look for possible manufacturer re-calls on components that could be in this home. Always consider hiring the appropriate expert for any repairs or further inspection.

### 6.5 COUNTERS AND CABINETS (REPRESENTATIVE NUMBER)

#### Repair or Replace

(2) Cabinet door hardware is noted to be loose at a kitchen cabinet doors. We recommend necessary corrections where needed by a qualified person.

### 6.8 SAFETY GLASS (INTERIOR)

#### Repair or Replace

The windows located with in the stairwell landing do not appear to have safety tempered glass as required. I could not find any markings on the glass which would confirm this safety feature. Having standard plate glass could cause serious injury if the glass breaks. While this may have been standard installation at the time of the original construction. We recommend upgrading the glass to tempered glass by a qualified licensed window contractor as a safety upgrade.

### 6.9 INTERIORS - OTHER

#### Inspected

(2) MAINTENANCE RECOMMENDATION: We recommend re sealing (caulking or grouting) around all sink to counter top junctions and backsplash to countertop junctions, and around all bathroom shower pan(s), curb(s), tub/ shower floor junctions, and adjacent walls throughout the house or where needed by a qualified person to help prevent moisture intrusion in these areas.

## 7. Plumbing System

### 7.2 WATER SUPPLY, DISTRIBUTION SYSTEMS

#### Inspected

(1) It was common practice for homes to have some portions of the plumbing distribution system installed through the concrete slab which have been known to deteriorate and result in leaks. During

the inspection, we tried to determine if any slab leaks may exist. At the time of the inspection, we scanned the slab using a thermal camera to help find any active leaks and there was no evidence of current/ active leaks observed or discovered.

(2) A corroded pipe is observed in the garage. We recommend further evaluation by a qualified licensed plumber and necessary repairs made.

### **7.3 WATER PRESSURE/ REGULATOR**

#### **Repair or Replace**

The water pressure was checked with a water pressure gauge and was measured to be higher than 80 PSI at the time of the inspection. This is too high and corrections are needed. We recommend further evaluation by a qualified licensed plumber for necessary repairs or corrections.

### **7.4 HOSE SPIGOT(S)**

#### **Repair or Replace**

(2) The exterior hose spigots do not have anti-siphon or anti-backflow devices installed on them. These anti-siphon or anti-backflow devices help prevent contaminated water from flowing back into the house water supply system. We recommend installing anti-siphon or anti-backflow devices at the every exterior hose spigots by a qualified person.

(3) The deck hose spigot is leaking when the water is turned on. We recommend necessary repairs or replacement by a qualified licensed plumber.

## **8(A) . Bathroom(s) / Hall Bathroom**

### **8.0.A SINK(S)**

#### **Repair or Replace**

The sink in the bathroom was slow draining at the time of the inspection This may indicate a blockage in the drain line. We recommend further evaluation by a qualified licensed plumber and repairs as needed.

### **8.1.A SHOWER**

#### **Repair or Replace**

The shower head leaks when the water is running through it. We recommend replacement by a qualified person.

### **8.2.A TUB**

#### **Repair or Replace**

(1) The tub diverter did not operate properly when tested. This is likely due from hard water deposit build up on the tub spout mechanism. We recommend necessary repairs or replacement by a licensed plumber.

(2) The tub stopper is missing. We recommend replacing by a qualified person.

## **8(B) . Bathroom(s) / Master Bathroom**

### **8.0.B SINK(S)**

#### **Repair or Replace**

(1) The metal portions of the sink drain are rusted or corroded. A leak was not observed at this sink drain pipe at the time of the inspection. However, we recommend replacing this drain pipe by a qualified licensed plumber to help prevent future leaks or damage.

(2) Some of the sink angle stop valves are observed with calcium deposits on them. Calcium deposits can corrode or deteriorate these valves and cause potential leaks. We recommend replacing all calcified angle stop valves by a qualified licensed plumber to help prevent leaks.

### **8.1.B SHOWER**

#### **Repair or Replace**

The shower head leaks when the water is running through it. We recommend replacement by a

qualified person.

## 9. Laundry

### 9.0 WASHING MACHINE/ DRYER CONNECTION(S)

#### Inspected

(1) There is a three prong 220 volt receptacle installed for the dryer. Most new electric dryers require a four prong receptacle. If you install an electric dryer, you may need to upgrade the receptacle or the dryer power cord. We recommend necessary corrections by a qualified licensed electrician.

(3) The hot and cold laundry water shut off valves are older gate valves. These gate valves can become "seized" due to lack of regular use and/ or calcium build up. Home inspectors do not test these valves as they may leak if turned. We recommend replacing these gate valves with ball type water shut off valves by a qualified licensed plumber.

### 9.1 CLOTHES DRYER VENT

#### Inspected

We recommend having the dryer vent cleaned by a qualified person.

## 10. Fireplaces/ Chimneys

### 10.0 CHIMNEY(S)

#### Inspected

We recommend having the fireplace and chimney cleaned and inspected by a licensed chimney sweep for safety prior to using.

### 10.2 DAMPER/ DAMPER CLAMP

#### Inspected

A damper clamp is not installed at the family room fireplace damper door. A damper clamp is required to be installed at a damper door when there is a gas supply to the fireplace(s). This damper clamp help prevents the damper from closing all the way as a safety precaution. If the damper is closed, Carbon Monoxide gas could enter the living space easier which is undetectable. SDG&E now requires damper clamps at all fireplaces damper doors. We recommend installation of a damper clamp by a qualified person.

### 10.3 HEARTH/ MANTLE

#### Inspected

The hearth at the front of the fireplace is missing/ of inadequate size/ or an improper material. This condition does not comply with current building and fire and safety requirements. We recommend installation of a properly sized hearth by a qualified licensed contractor.

## 11. Detectors, Safety, Security

### 11.0 SMOKE DETECTORS

#### Inspected

(1) We recommend installing additional smoke detectors where needed to comply with current fire and safety standards and regulations as a safety upgrade.

(2) The smoke detectors in the property are older. Studies show that detectors that are more than 10 years old have a high rate of failure. Many old detectors do not have battery back-up, and will not work if the electricity is off. We recommend that all old detectors be replaced prior to occupancy of the house for safety.

### 11.1 CARBON MONOXIDE DETECTOR(S)

#### Inspected

(2) The quantity of Carbon Monoxide detectors that are required to be installed varies with each house. Larger houses, or those with multiple levels are required to have more CO detectors. A Carbon Monoxide detector is required on each level of a multi-level house and adjacent to each cluster of bedrooms. We recommend installing additional Carbon Monoxide detectors where needed.

## 12. Heating Equipment

### 12.0 HEATING EQUIPMENT

#### Inspected

(2) The furnace is older but did work at the time of the inspection. I was unable to determine life remaining. Most HVAC contractors state that furnaces that are 20 years old or older are more likely to be at the end of their useful life. We therefore recommend that you have this furnace inspected and serviced by a qualified licensed HVAC contractor to make sure that it is safe, and to obtain an estimate of life remaining, and a cost of replacement prior to the end of your contingency period. We also recommend that you keep a good home warranty in place, which covers the furnace.

(3) The gas supply pipe at the furnace did not contain a drip leg/ sediment trap. This may have been standard at the time of installation but now is highly recommended. The purpose of a drip leg is to help prevent sediment/ debris from entering and clogging the furnace gas valve which could cause the furnace to shut down. We recommend having a drip leg installed by a qualified licensed HVAC contractor.

(4) The flexible gas supply pipe passes through the furnace housing. Vibration from the furnace can wear through flexible gas pipe which could cause a gas leak. SDG&E is "Red Tagging" this condition as they considered it to be unsafe. Due to this condition we recommend a rigid cast pipe be installed from the gas regulator through furnace housing, to the exterior of furnace housing by a qualified licensed HVAC contractor.

### 12.1 THERMOSTAT(S)

#### Inspected

(2) The thermostat batteries are weak or dead. We recommend replacement by a qualified person.

## 13. Cooling Equipment

### 13.0 COOLING EQUIPMENT

#### Repair or Replace

(3) The AC system is 15 or more years old and may be near the end of its useful life. The average life of an AC system is approximately 10-15 years. We recommend further evaluation and servicing by a qualified licensed HVAC contractor to determine life remaining and potential cost to replace so that you can budget accordingly. We also recommend that you keep a good home warranty in place, which covers the AC system.

(5) The insulation is missing at the exterior refrigerant lines. We recommend replacing the missing insulation by a qualified person.

### 13.1 CONDENSATE EQUIPMENT

#### Inspected

A vented trap was not installed in the condensation drain line. A vented trap must be installed in the condensation drain line to prevent vapor lock and possible condensation leaks in the house. We recommend installation of a vented trap by a qualified licensed HVAC contractor.

## 16. Built-In Kitchen Appliances

### 16.1 FOOD WASTE DISPOSER

#### Inspected

(2) The food waste disposal drain is installed in a non-standard manner. The drain tube exiting the disposer is installed horizontally and intersects the drain line of the other sink basin with a "T" fitting,



then down to the P-trap. This can cause waste from the disposer to rise into the opposite sink basin before draining. We recommend necessary corrections by a qualified licensed plumber.

---

Home inspectors are not required to report on the following: Life expectancy of any component or system; The causes of the need for a repair; The methods, materials, and costs of corrections; The suitability of the property for any specialized use; Compliance or non-compliance with codes, ordinances, statutes, regulatory requirements or restrictions; The market value of the property or its marketability; The advisability or inadvisability of purchase of the property; Any component or system that was not observed; The presence or absence of pests such as wood damaging organisms, rodents, or insects; or Cosmetic items, underground items, or items not permanently installed. Home inspectors are not required to: Offer warranties or guarantees of any kind; Calculate the strength, adequacy, or efficiency of any system or component; Enter any area or perform any procedure that may damage the property or its components or be dangerous to the home inspector or other persons; Operate any system or component that is shut down or otherwise inoperable; Operate any system or component that does not respond to normal operating controls; Disturb insulation, move personal items, panels, furniture, equipment, plant life, soil, snow, ice, or debris that obstructs access or visibility; Determine the presence or absence of any suspected adverse environmental condition or hazardous substance, including but not limited to mold, toxins, carcinogens, noise, contaminants in the building or in soil, water, and air; Determine the effectiveness of any system installed to control or remove suspected hazardous substances; Predict future condition, including but not limited to failure of components; Since this report is provided for the specific benefit of the customer(s), secondary readers of this information should hire a licensed inspector to perform an inspection to meet their specific needs and to obtain current information concerning this property.

*Prepared Using HomeGauge <http://www.HomeGauge.com> : Licensed To Jeff Duncan*